

Manual de montagem / Plano de armado

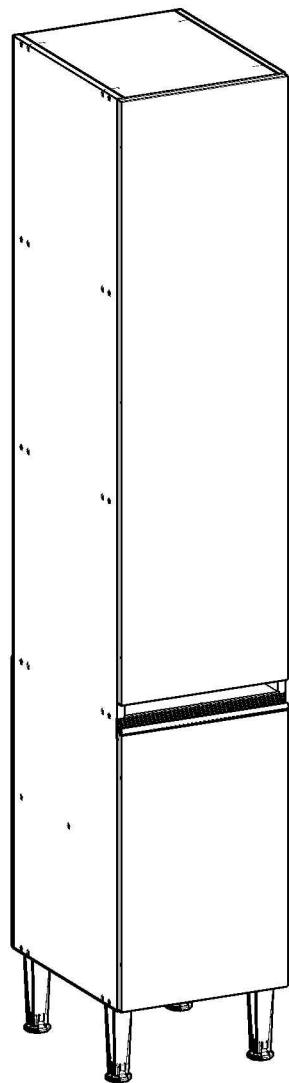

Ref.: 1308M

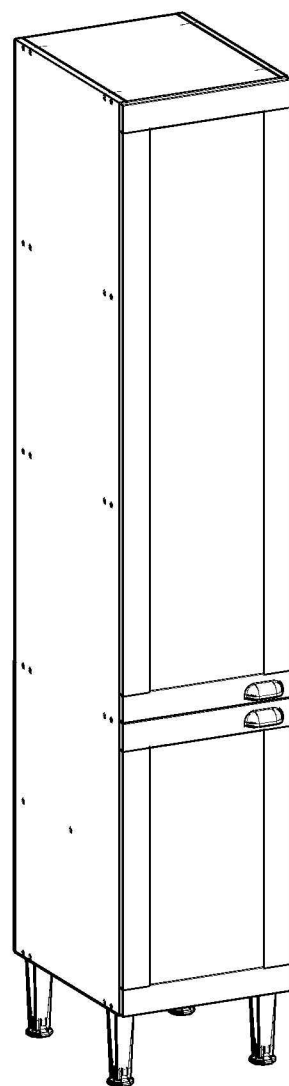

Ref.: 1308P

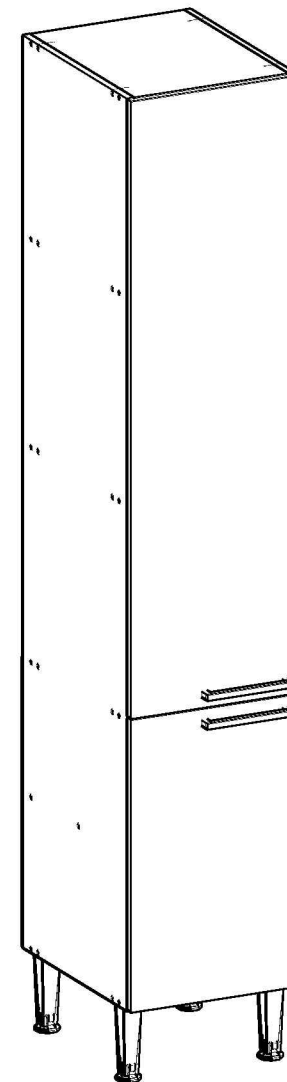

Ref.: 1308L

Parabéns! Você comprou um produto de excelente qualidade, fabricado com chapa de madeira de MDP ou MDF, extraída de florestas renováveis. Possui alta resistência e design atual.

Felicitaciones! Usted compró a un producto de excelente calidad, fabricado con placa de madera de MDP o MDF, proveniente de florestas renovables. Tiene alta resistencia y diseño actual.

Antes de montar o móvel, leia com atenção o manual de montagem!

Antes de armar el mueble, lea con atención el manual de ensamble!



ATENÇÃO:
ATENCIÓN:

1) Verifique todas as peças antes de começar a montagem.

Verifique todas las partes antes de empezar el armado.

2) Ao começar a montagem, não apoie as peças na parede.

Al empezar el armado, no apoyes las partes en la pared.

3) Ao colocar as peças e ferragens de lado, cuidado para não perde-las.

Al poner las piezas y herrages a parte, cuidado para no dañarlas.

4) O móvel deve ser montado no chão, para isso, use a própria caixa para proteger e não danificar o piso.

El mueble suele ser armando al piso, para eso, use la propia caja para protegerlo y no dañar al piso.

5) Comece a montagem seguindo as instruções passo a passo.

Comience el armado siguiendo la instrucciones paso a paso.

6) É de responsabilidade do montador seguir as intrucões desse manual, que são fundamentais para a estrutura do móvel.

Es de responsabilidad del armador seguir las instrucciones de este manual, que son fundamentales para la estructura del mueble.

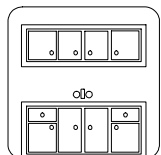

CUIDADOS:
CUIDADOS:

1) A conservação e limpeza deve ser feita com um pano levemente umedecido com água.

La conservación y limpieza debe ser hecha con un trapo levemente humedecido en agua.

2) Não use produtos abrasivos, como saponáceo, detergentes e esponja de aço.

No use productos abrasivos, como saponáceo, detergentes y esponja de acero.

3) Não use cera ou óleo para dar brilho ao móvel.

No use cera o aceites para darle brillo al mueble.





4) Não expor o móvel a interpéries e nem ao calor excessivo.

No exponer el mueble a interperies ni al calor excesivo.

5) Ao terminar a montagem, limpe o ambiente e o móvel.

Al terminar el armado, limpie al ambiente y al mueble.

FERRAMENTAS:
HERRAMIENTAS:

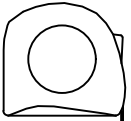





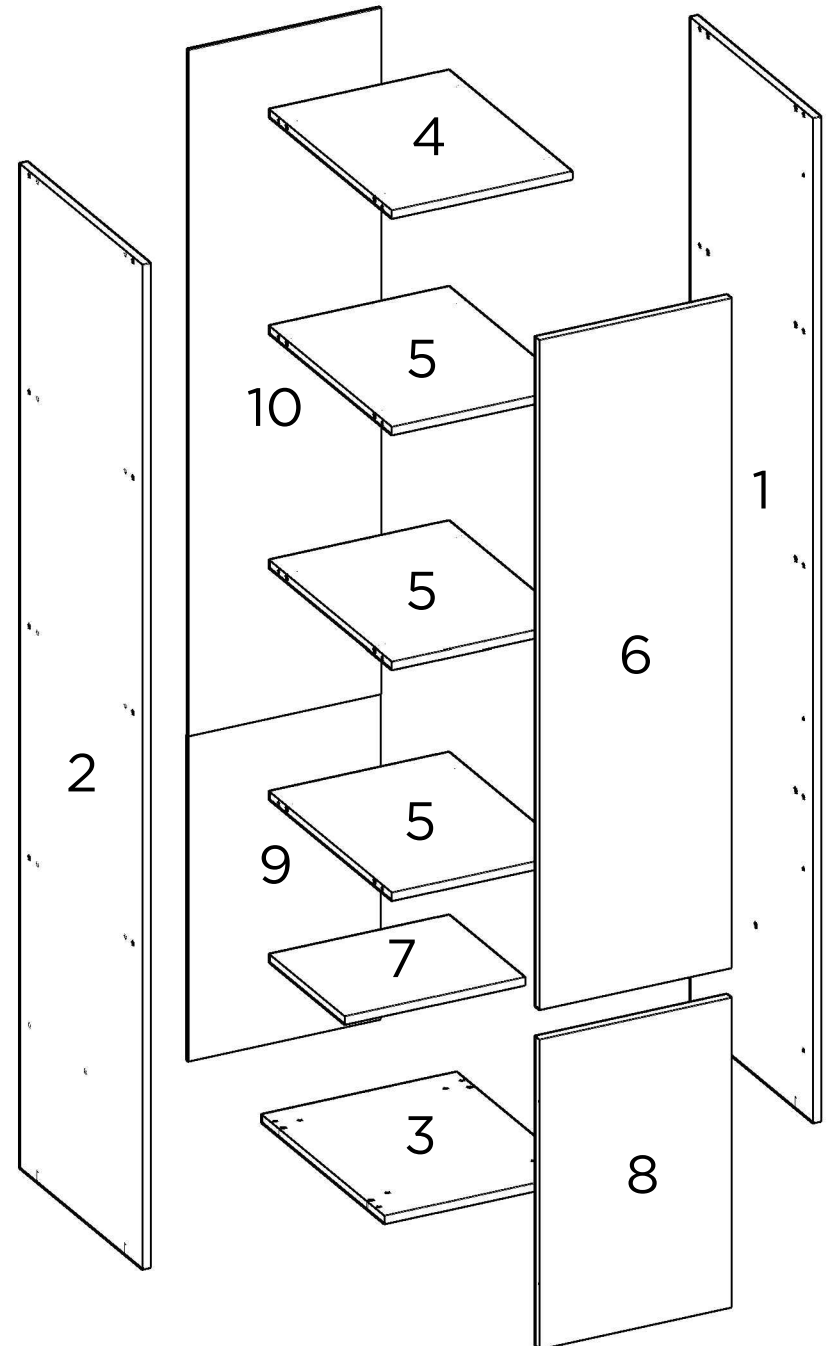



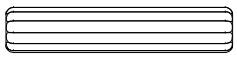

 Parafusadeira Destornillador Eléctrico	 Martelo de borracha Martillo Goma	 Martelo Martillo
 Chave Phillips Llave Phillips	 Trena Cinta métrica	

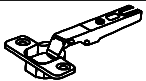
PEÇAS / PARTS / PIEZAS

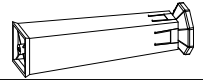
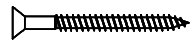
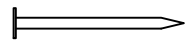
Nº No Num	DESCRIÇÃO DESCRIPTION DESCRIPCIÓN	QTD QTY CANT
1	LATERAL DIREITA RIGHT SIDE PANEL LATERAL DERECHA	1
2	LATERAL ESQUERDA LEFT SIDE PANEL LATERAL IZQUIERDA	1
3	BASE BOTTOM BASE	1
4	TAMPO TOP TABLERO	1
5	PRATELEIRA FIXA FIXED PLATE REPISA FIJO	3
6	PORTA SUPERIOR UPPER DOOR PUERTA SUPERIOR	1
7	PRATELEIRA MÓVEL MOBILE PLATE REPISA MÓVIL	1
8	PORTA DOOR PUERTA	1
9	COSTA INFERIOR LOWER BACK PANEL TRASERO INFERIOR	1
10	COSTA SUPERIOR UPPER BACK PANEL TRASERO SUPERIOR	1

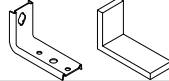

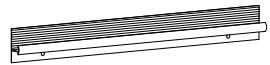
FERRAGENS / HARDWARE / HERRAJES

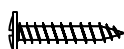
CÓD CODE COD	DESCRIÇÃO DESCRIPTION DESCRIPCIÓN	QTD QTY CANT
A	 CAVILHA WOODEN DOWEL TARUGO	20
B	 SUPORTE DE PRATELEIRA SHELF SUPPORT SOPORTE DE ESTANTES	4
C	 PARAFUSO 4X14mm SCREW 4X14mm TORNILLO 4X14mm	26
D	 CALÇO PARA DOBRADIÇA HINGE SHED CALZO DE BISAGRA	5
E	 DOBRADIÇA HINGE BIZAGRA	5
F	 PARAFUSO 5X50mm SCREW 5X50mm TORNILLO 5X50mm	5
G	 PÉ LEG PATA	4
H	 PARAFUSO 3,5X40mm SCREW 3,5X40mm TORNILLO 3,5X40mm	20
I	 PREGO NAIL CLAVO	53
J	 GARRA METÁLICA METALLIC CLAW GRAB METALICA	3
K	 SUPORTE DE FIXAÇÃO MOUNTING SUPPORT SOPORTE DE MONTAJE	1
L	 BUCHA PLÁSTICA PLASTIC BUSHING CASQUILLO PLÁSTICO	1
M	 PUXADOR PULLER TIRADOR	2
N	 PARAFUSO 3.5X25mm SCREW 3.5X25mm TORNILLO 3.5X25mm	2
O	 PARAFUSO 3.5X25mm SCREW 3.5X25mm TORNILLO 3.5X25mm	4

UTILIZE A RÉGUA PARA IDENTIFICAR OS PARAFUSOS
USE THE RULER TO IDENTIFY THE SCREWS
UTILICE LA REGLA PARA IDENTIFICAR LOS TORNILLOS

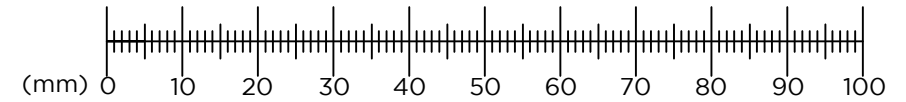

PESO SUPORTADO / WEIGHT SUPPORTED / PESO SOPORTADO

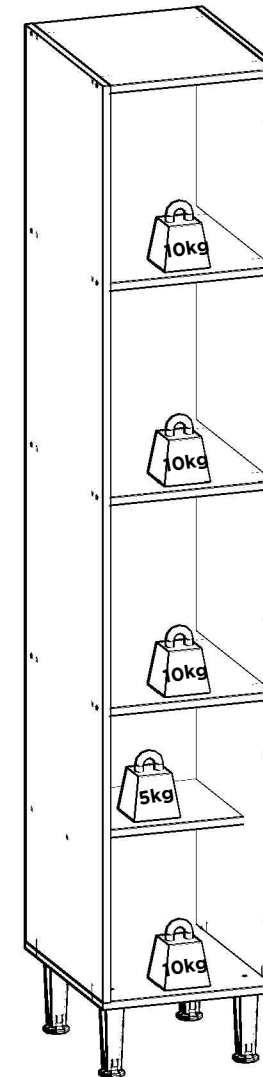

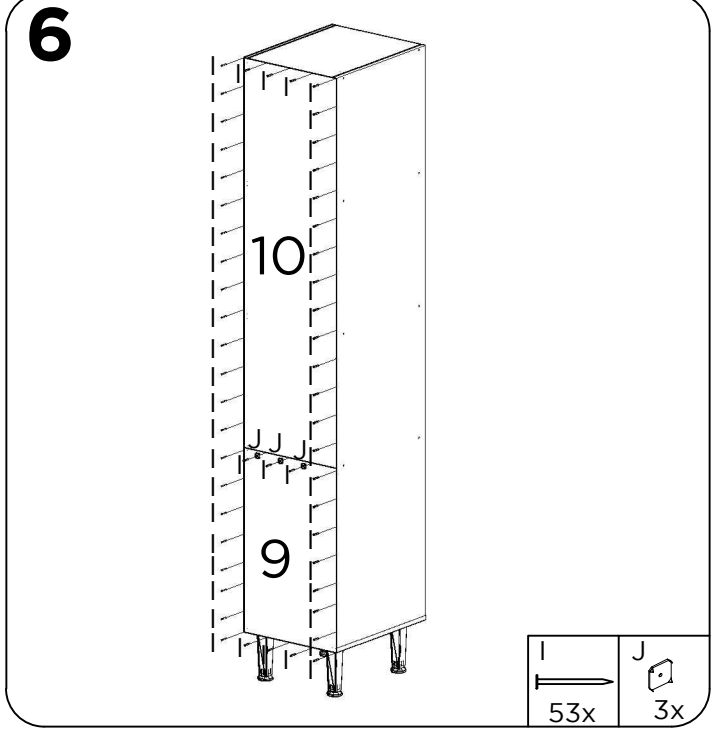
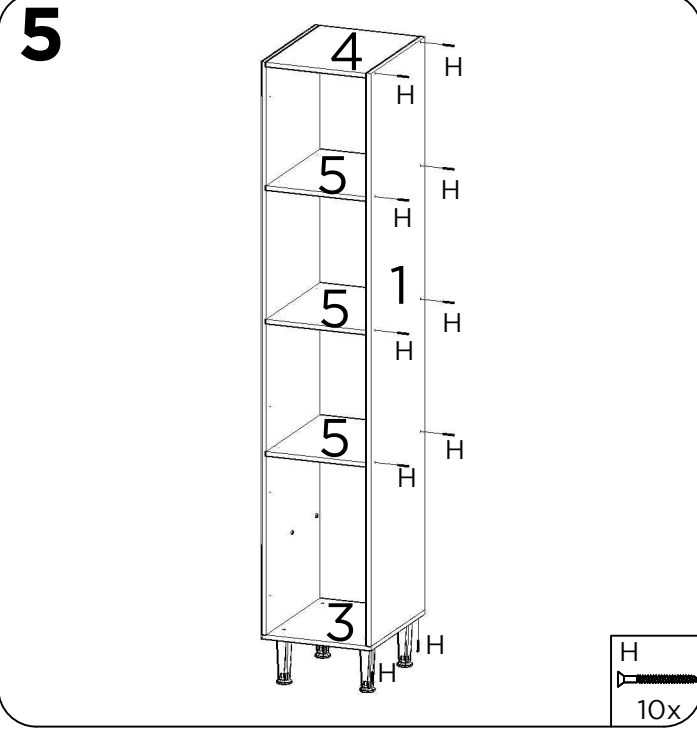
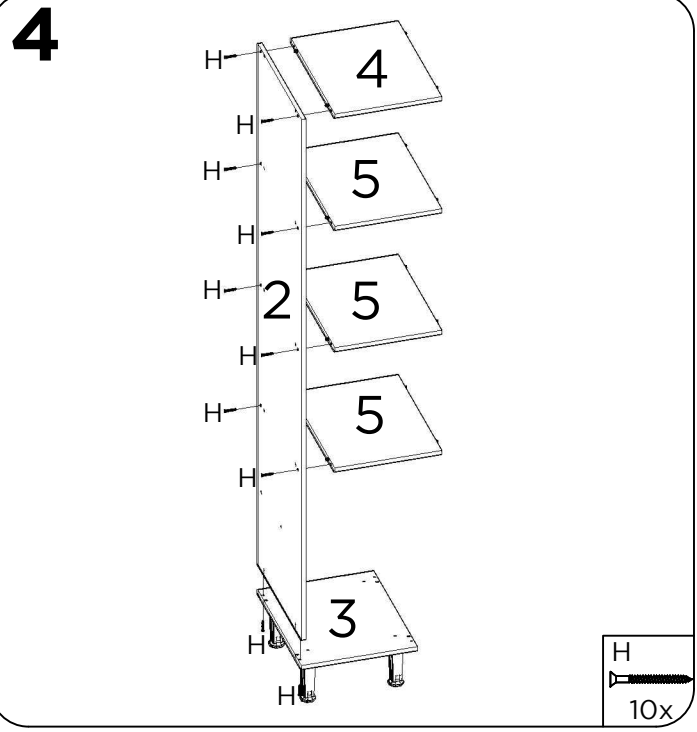
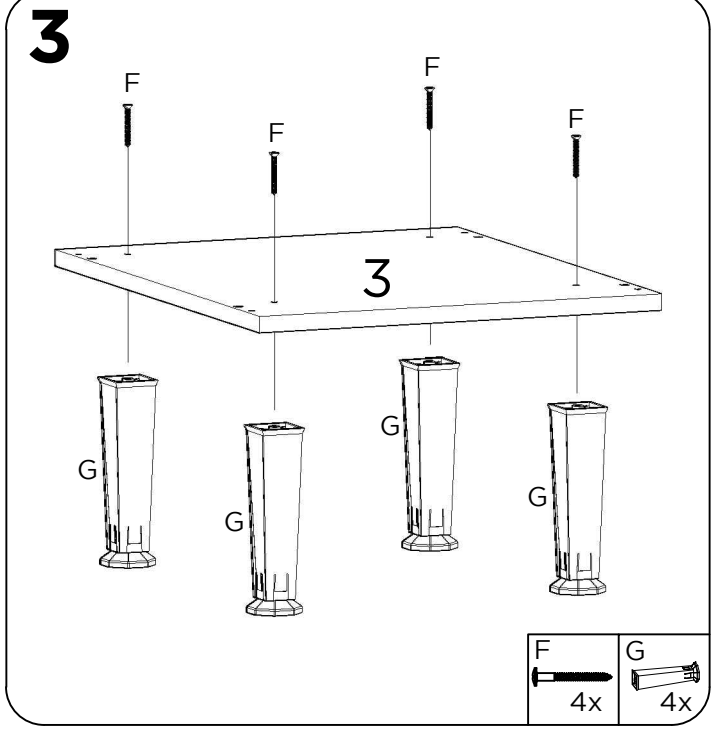
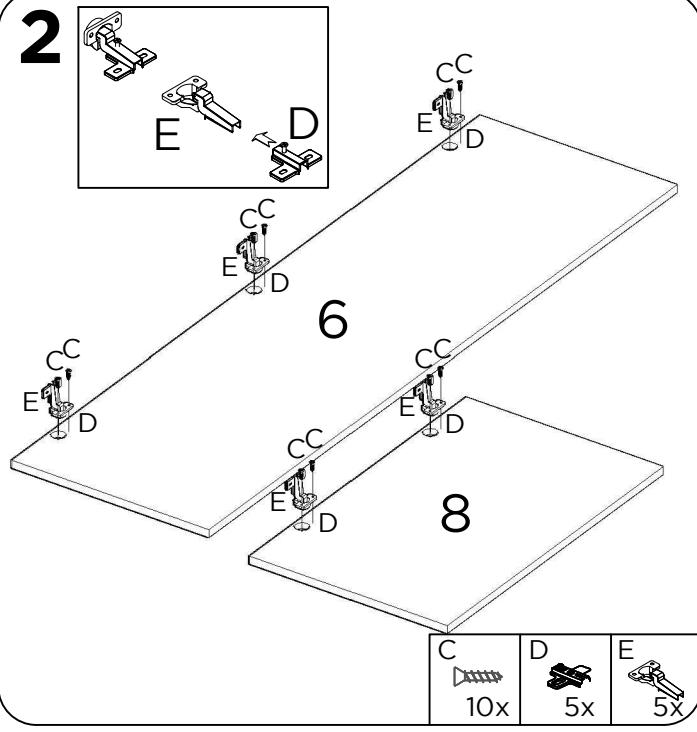
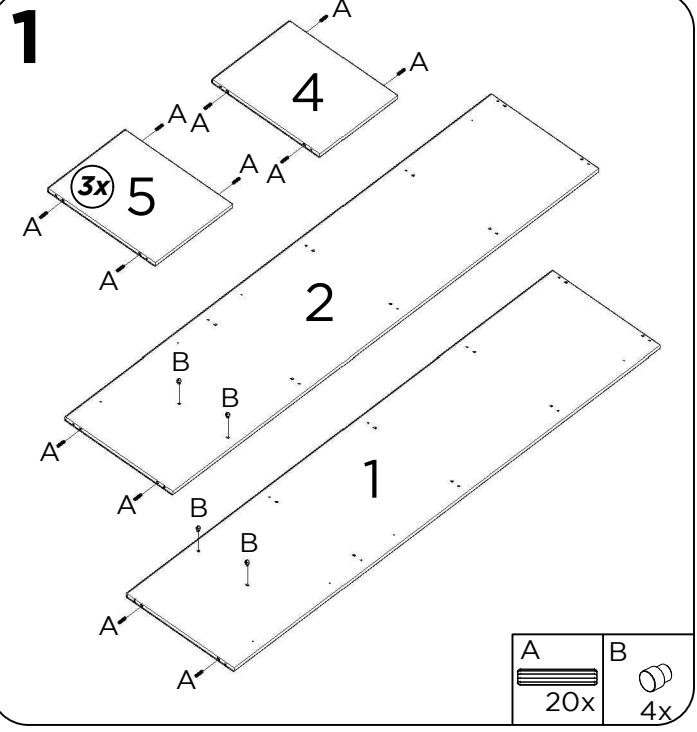

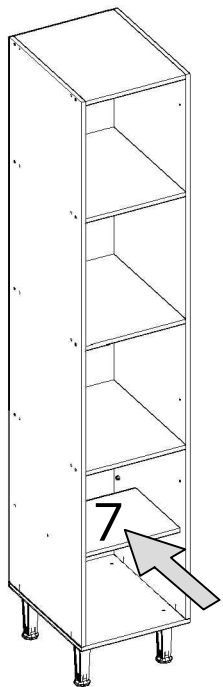
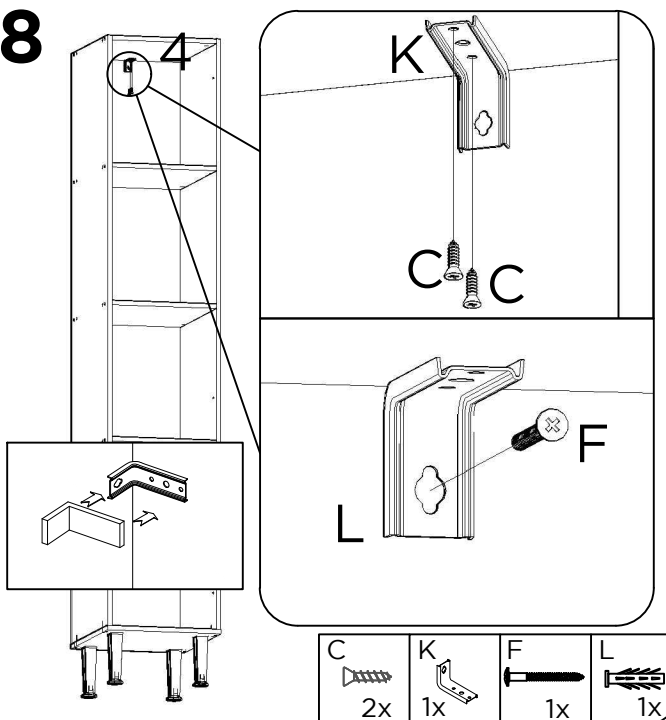
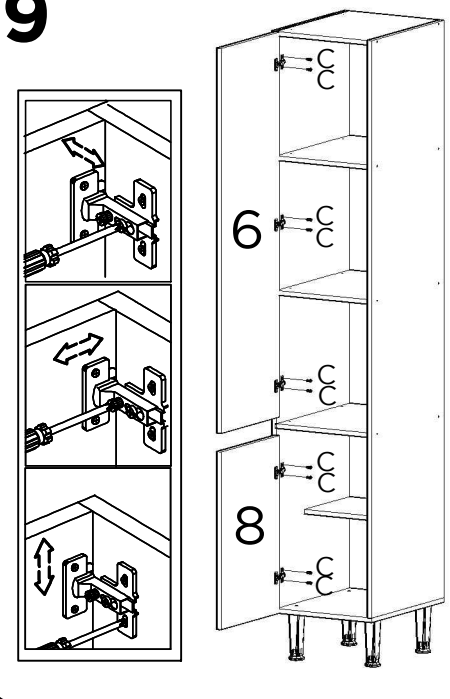
7**8****9****10**

Instalação dos puxadores conforme modelo adquirido, siga os passos no manual dos puxadores.
Instalación de las manijas según el modelo adquirido, seguir los pasos del manual de manijas.

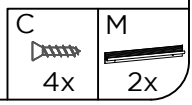
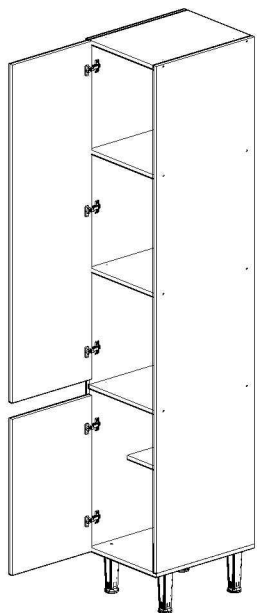
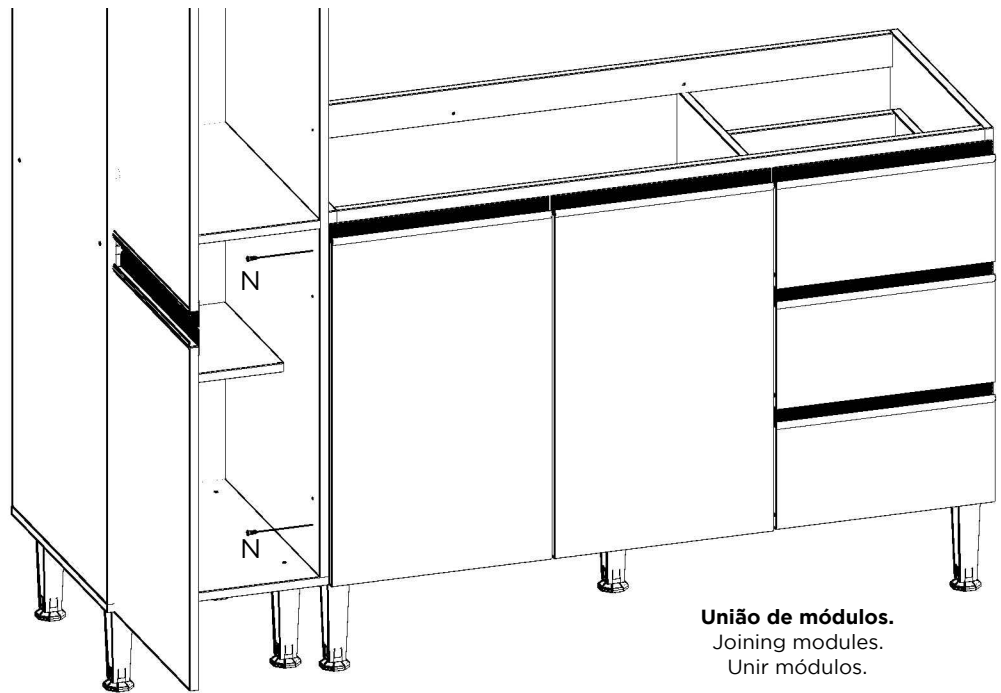
**11**

União de módulos.
 Joining modules.
 Unir módulos.

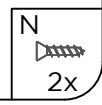

Instalação do puxador. Instalación del tirador

Siga a instrução de montagem do puxador segundo o modelo adquirido. Utilizando as respectivas ferragens.

Siga las instrucciones de montaje del tirador según el modelo adquirido. Usar correctamente la herraje.

