

Manual de montagem / Plano de armado

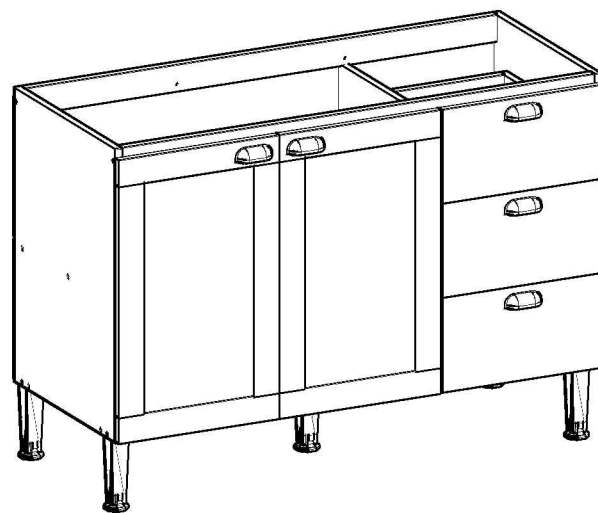

Ref.: 1303M



Ref.: 1303P

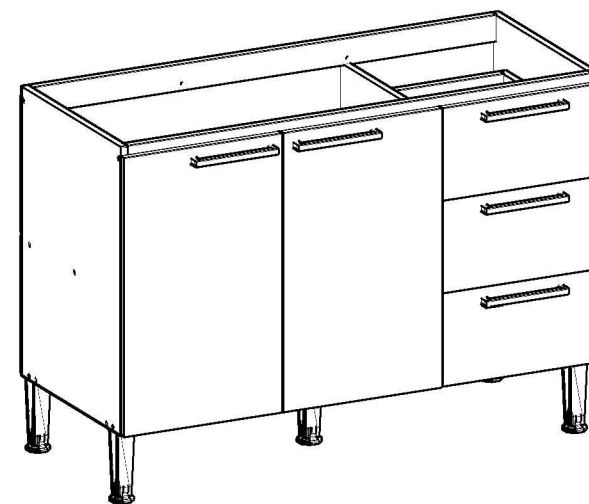

Ref.: 1303L

Parabéns! Você comprou um produto de excelente qualidade, fabricado com chapa de madeira de MDP ou MDF, extraída de florestas renováveis. Possui alta resistência e design atual.

Felicitaciones! Usted compró a un producto de excelente calidad, fabricado con placa de madera de MDP o MDF, proveniente de florestas renovables. Tiene alta resistencia y diseño actual.

Antes de montar o móvel, leia com atenção o manual de montagem!

Antes de armar el mueble, lea con atención el manual de ensamble!



ATENÇÃO:
ATENCIÓN:

1) Verifique todas as peças antes de começar a montagem.

Verifique todas las partes antes de empezar el armado.

2) Ao começar a montagem, não apoie as peças na parede.

Al empezar el armado, no apoyes las partes en la pared.

3) Ao colocar as peças e ferragens de lado, cuidado para não perde-las.

Al poner las piezas y herrages a parte, cuidado para no dañarlas.

4) O móvel deve ser montado no chão, para isso, use a própria caixa para proteger e não danificar o piso.

El mueble suele ser armando al piso, para eso, use la propia caja para protegerlo y no dañar al piso.

5) Comece a montagem seguindo as instruções passo a passo.

Comience el armado siguiendo la instrucciones paso a paso.

6) É de responsabilidade do montador seguir as intrucões desse manual, que são fundamentais para a estrutura do móvel.

Es de responsabilidad del armador seguir las instrucciones de este manual, que son fundamentales para la estructura del mueble.

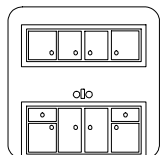

CUIDADOS:
CUIDADOS:

1) A conservação e limpeza deve ser feita com um pano levemente umedecido com água.

La conservación y limpieza debe ser hecha con un trapo levemente humedecido en agua.

2) Não use produtos abrasivos, como saponáceo, detergentes e esponja de aço.

No use productos abrasivos, como saponáceo, detergentes y esponja de acero.

3) Não use cera ou óleo para dar brilho ao móvel.

No use cera o aceites para darle brillo al mueble.



4) Não expor o móvel a interpéries e nem ao calor excessivo.

No exponer el mueble a interperies ni al calor excesivo.







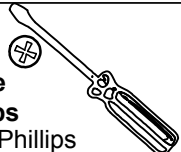
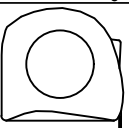



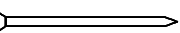

5) Ao terminar a montagem, limpe o ambiente e o móvel.

Al terminar el armado, limpie al ambiente y al mueble.

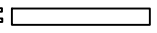
FERRAMENTAS:
HERRAMIENTAS:

 Parafusadeira Destornillador Eléctrico	 Martelo de borracha Martillo Goma	 Martelo Martillo
 Chave Phillips Llave Phillips	 Trena Cinta métrica	

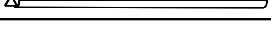
Ítem	Descrição / Descripción / Description	Qtd.
1	Lateral direita / Lateral derecha / Right side	1
2	Lateral esquerda / Lateral izquierda / Left side	1
3	Prateleira / Repisa / Shelf	1
4	Divisória / Divisoria / Division	1
5	Travessa frontal / Travesaño frontal / Frontal plate	1
6	Travessa traseira / Travesaño trasero / Back plate	1
7	Pilastra / Pilastra / Pillar	1
8	Porta / Puerta / Door	2
10	Frente de gaveta / Frente del cajón / Drawer front	3
11	Lateral de gaveta / Lateral del cajón / Drawer side	6
12	Costa de gaveta / Trasero del cajón / Drawer back	3
13	Base / Base / Bottom	1
14	Costa / Trasero / Back	2
15	Fundo de gaveta / Fondo del cajón / Drawer bottom	3

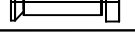
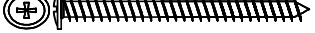
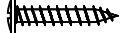
ITEM	LISTA DE FERRAGENS LISTA DE HERRAJES HARDWARE LIST	DESCRIÇÃO DESCRIPCIÓN DESCRIPTION	QTD.
C1		CAVILHA 6X30 / TARUGO 6X30 WOODEN DOWEL 6X30	18
P1		PARAFUSO 4X50 / TORNILLO 4X50 SCREW 4X50	10
P2		PARAFUSO 4X14 / TORNILLO 4X14 SCREW 4X14	100
P4		PARAFUSO 3,5X25 / TORNILLO 3,5X25 SCREW 3,5X25	7
S1		CHAPA "L" 2 FUROS / PLACA "L" 2 AGUJEROS PLATE "L" 2 HOLES	2
R1		PREGO 10X10 / CLAVO 10X10 NAIL 10X10	30
R2		PREGO ANELADOS / CLAVO ANILLADOS RINGED NAILS	42
H1		SUPORTE DE PRATELEIRA / SOPORTE DE REPISA SHELF SUPPORT	4
B1		PERFIL H / PERFIL H PROFILE H	1
D1		CALÇO DE DOBRADIÇA / CALZO DE BISAGRA HINGE SHIM	4
S2		CHAPA "L" 4 FUROS / PLACA "L" 4 AGUJEROS PLATE "L" 4 HOLES	10
D2		DOBRADIÇA / BISAGRA HINGE	4
U1		PUXADOR / TIRADOR HANDLE	5
M1		CORREDIÇA / CORREDERA SLIDE	3
PP		PÉ / PIE LEG	5
P5		PARAFUSO 5X50 / TORNILLO 5X50 SCREW 5X50	5
P5		PARAFUSO 3,5X25 / TORNILLO 3,5X25	10

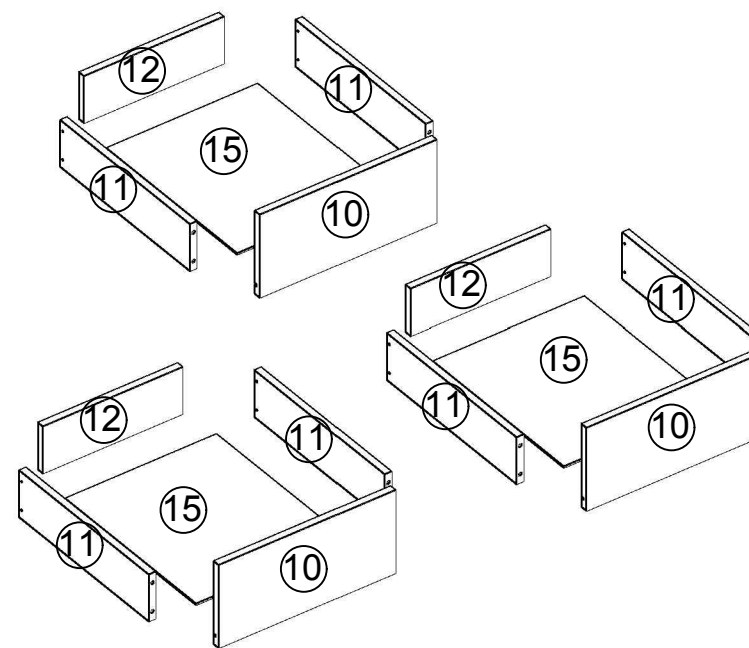
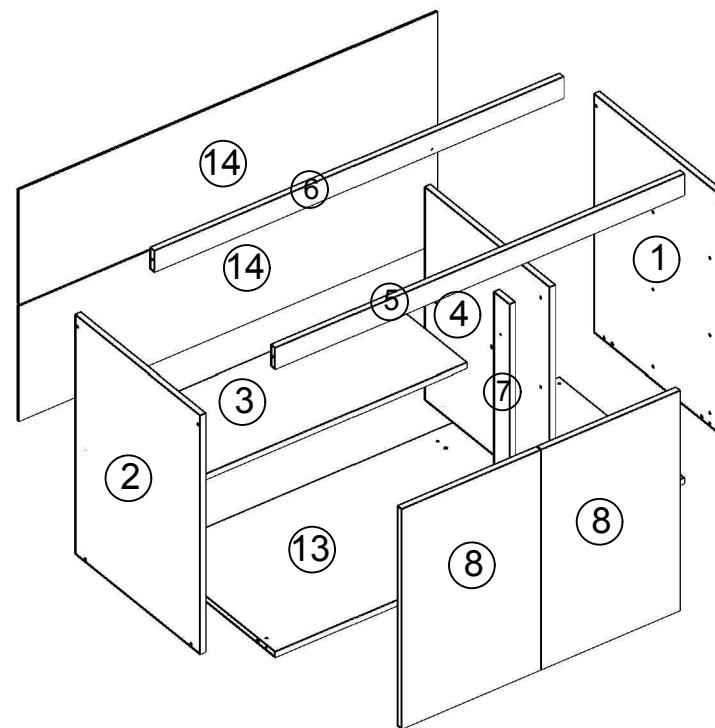

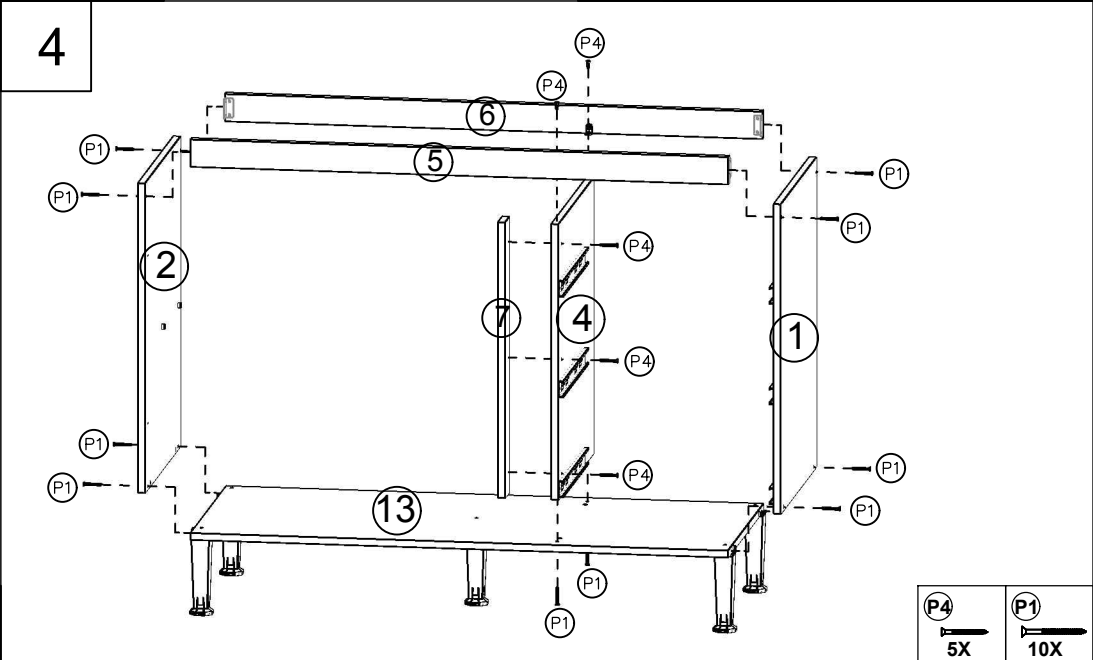
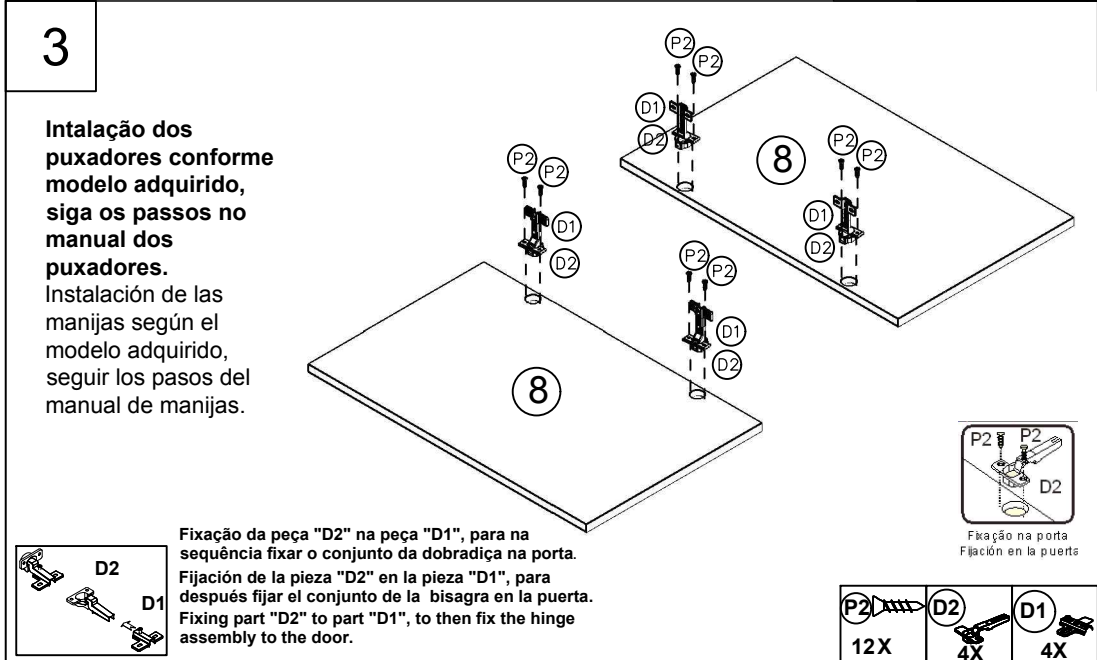
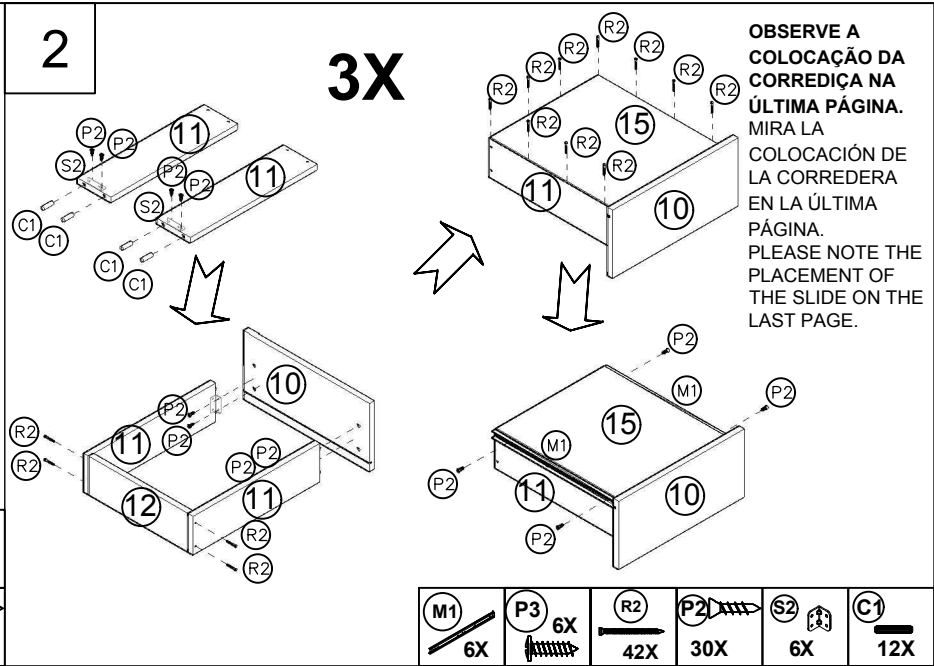
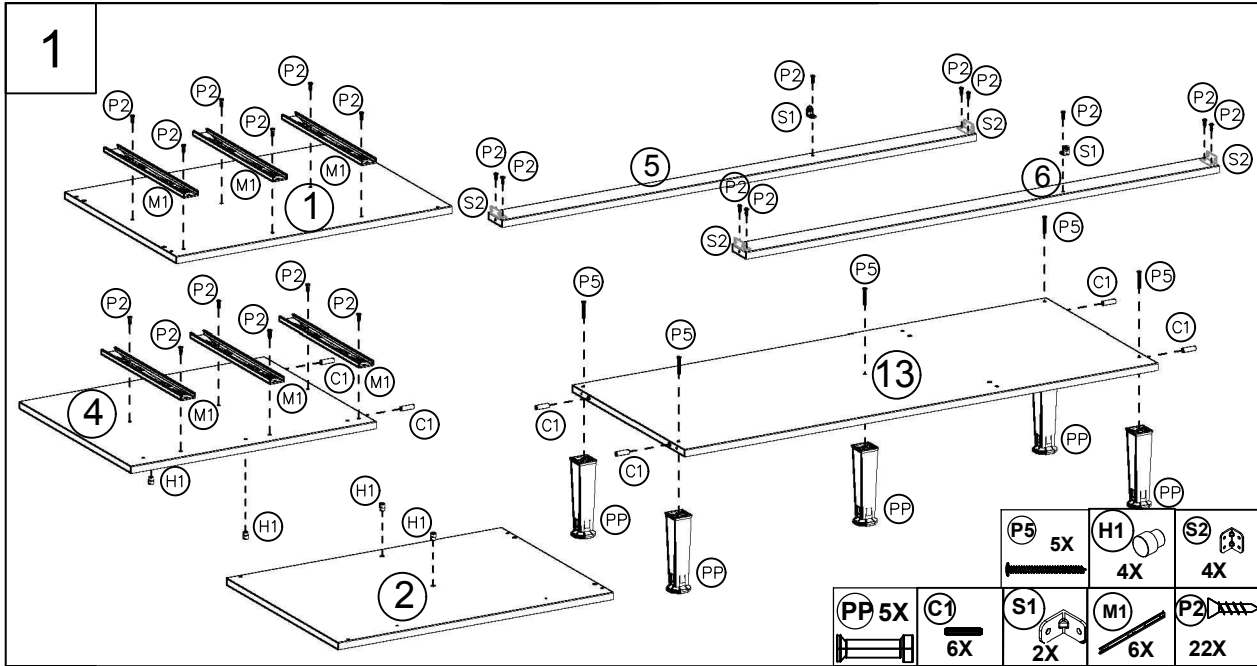

5

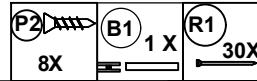
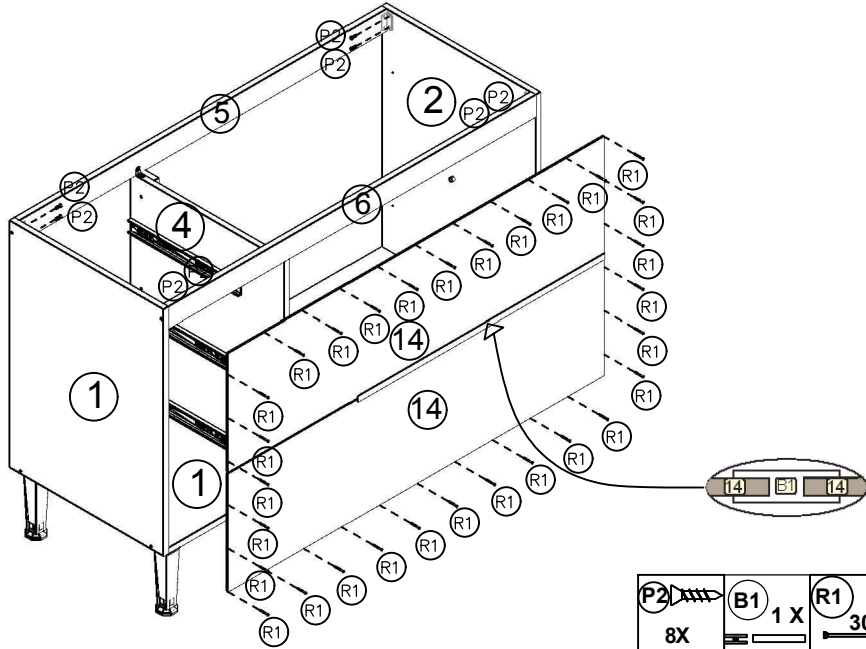

6

COLOQUE A PRATELEIRA (3)
PONGA LA REPISA (3)
INSTALL THE SHELF (3)

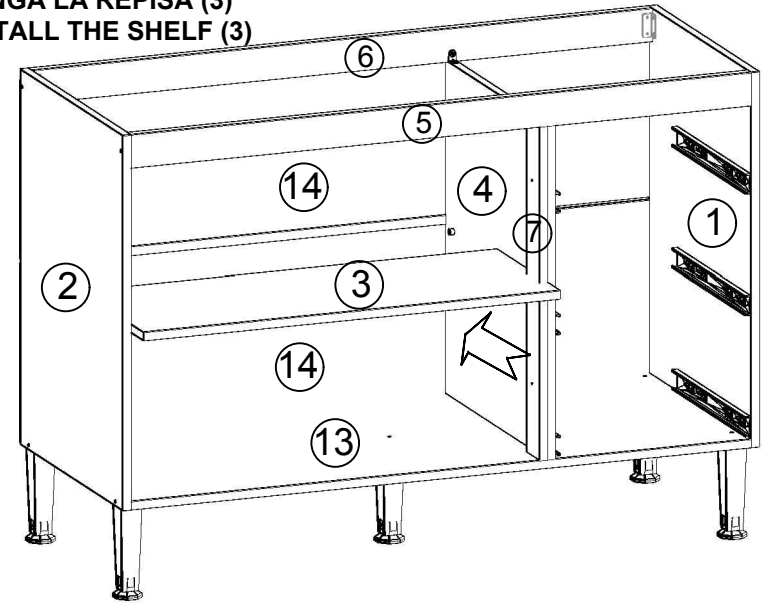

7

COLOQUE AS PORTAS (8)
PONGA LAS PUERTAS (8)
INSTALL THE DOORS (8)

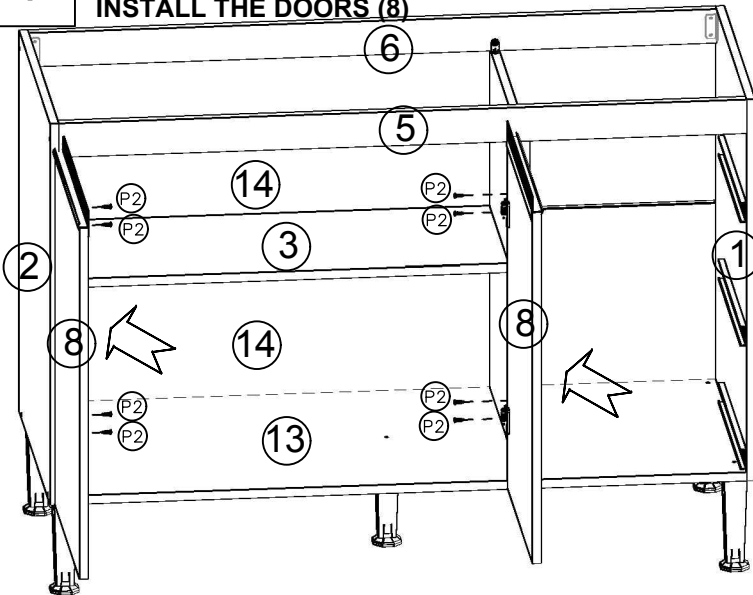

REGULAGEM DAS PORTAS
AJUSTE DE LAS PUERTAS
ADJUSTMENT OF THE DOORS

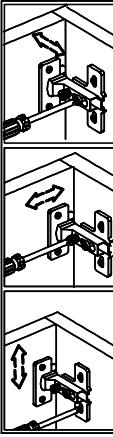

8

COLOQUE AS GAVETAS
PONGA LOS CAJONES
INSTALL THE DRAWERS

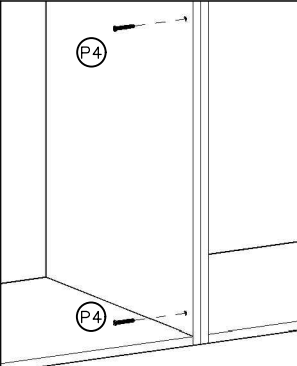
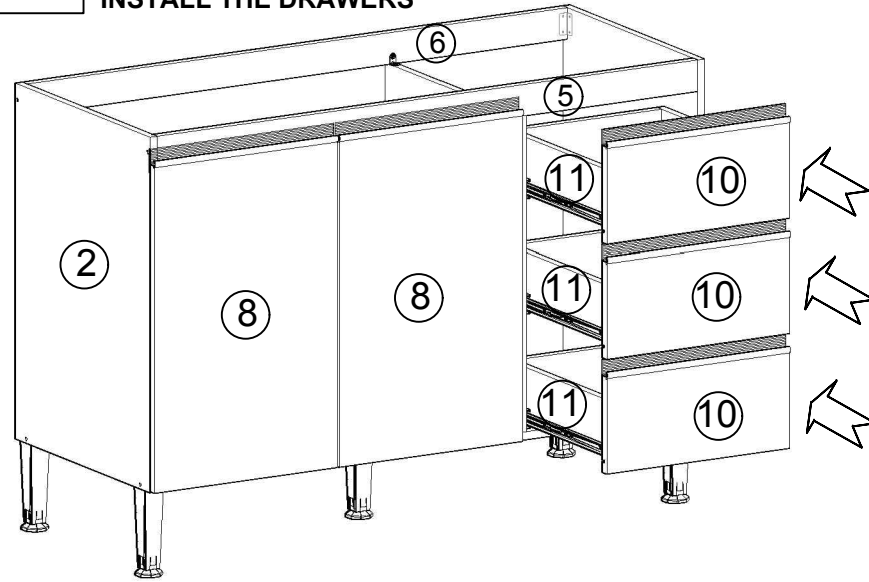

Para realizar a união entre diferentes módulos, fazer uso do parafuso "P4".
Para hacer la unión entre los diferentes módulos, utilice los tornillos "P4".
To join different modules, use the "P4" screw.



Para instalar as corredeças telescópicas é necessário seguir os passos, separando as partes que compõem a corredeça.

Para instalar las correderas telescópicas es necesario seguir los pasos, separando las dos partes que componen la pieza.

To install the telescopic slides, it is necessary to follow the steps, separating the parts that make up the slide.

Corredeça telescópica / Corredera telescópica / Telescopic slide



Passo 1 / Paso 1 / Step 1

Corredeça telescópica aberta / Corredera telescópica abierta / Telescopic slide open



Para separar as partes da corredeça, puxe o engate que está na parte traseira da corredeça (desenho ao lado) no sentido anti-horário, separando as duas partes, para facilitar a fixação no móvel.

Para separar las dos partes de la corredera, tire el engate que está en la parte de atrás de la corredera (dibujo al lado) en el sentido anti-horario, separando las dos partes, para facilitar la fijación en el mueble.

To separate the parts of the slide, pull the hook on the back of the slide (illustration on the side) counterclockwise, separating the two parts, to facilitate attachment to the furniture.

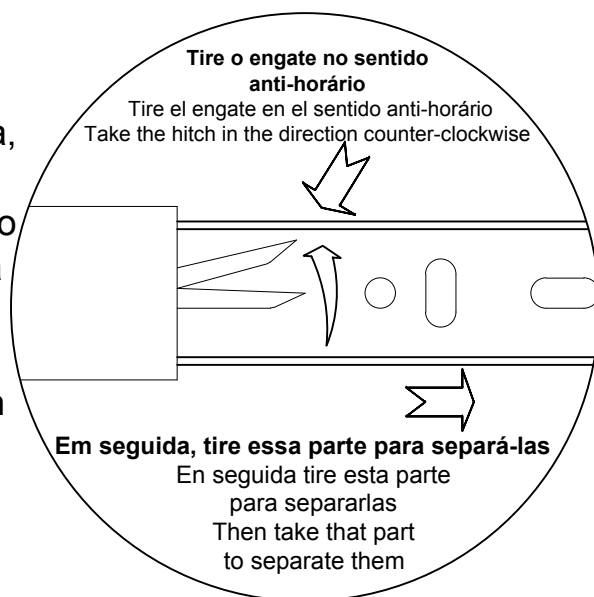
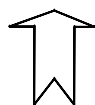

Passo 2 / Paso 2 / Step 2

Com as partes da corredeça separadas, fixar-las no móvel.

Con las partes de la corredera separadas, fijarlas en el mueble.

With the slide parts separated, fix them to the furniture.

Parte A

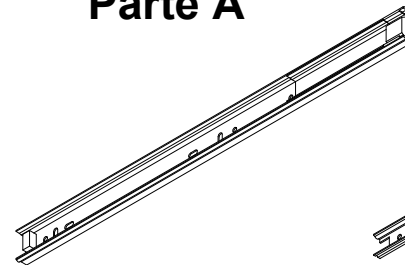

Parte B

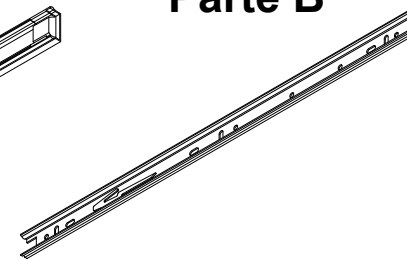

As corredeças devem ficar alinhadas com a parte inferior das laterais de gavetas.

Las correderas deben quedar aliñada con la parte inferior de las laterales de los cajones.

The runners should be flush with the underside of the drawer sides.

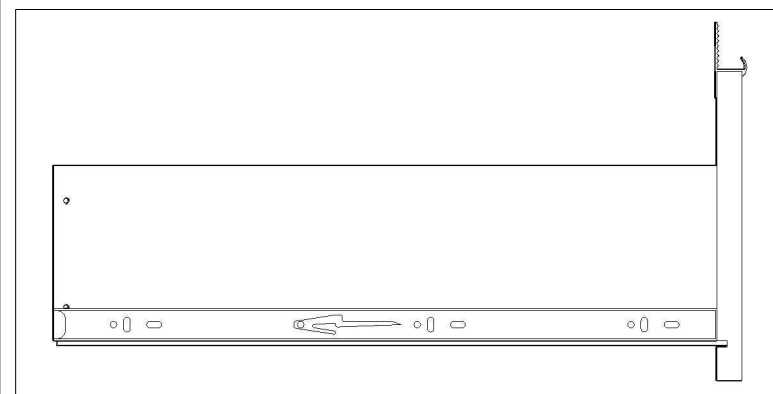

Instalação do puxador. Instalación del tirador

Siga a instrução de montagem do puxador segundo o modelo adquirido. Utilizando as respectivas ferragens.

Siga las instrucciones de montaje del tirador según el modelo adquirido. Usar correctamente la herraje.

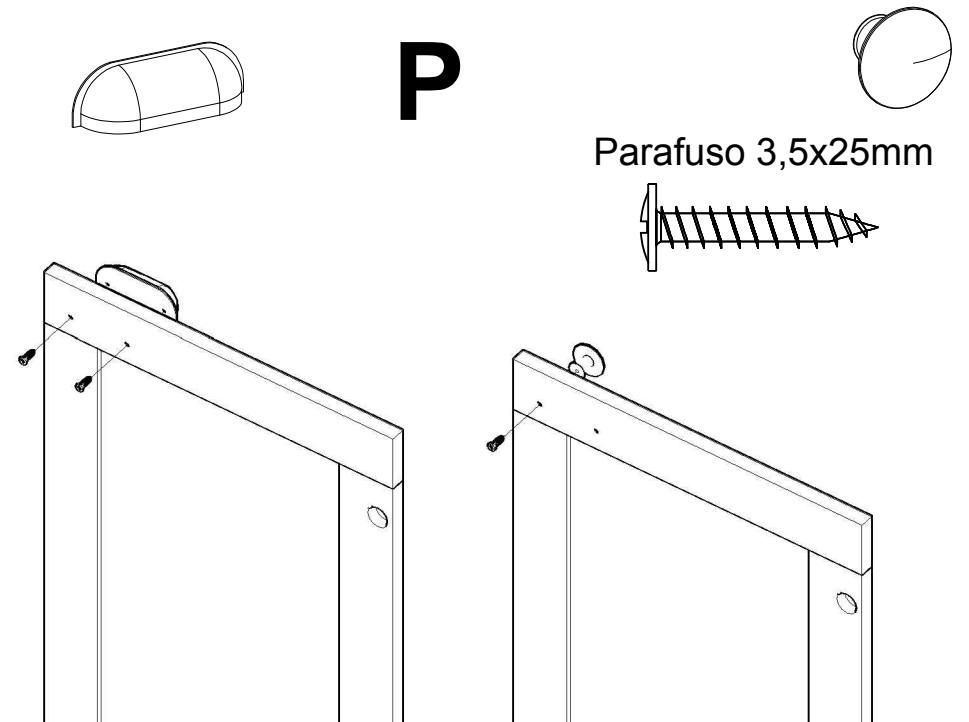
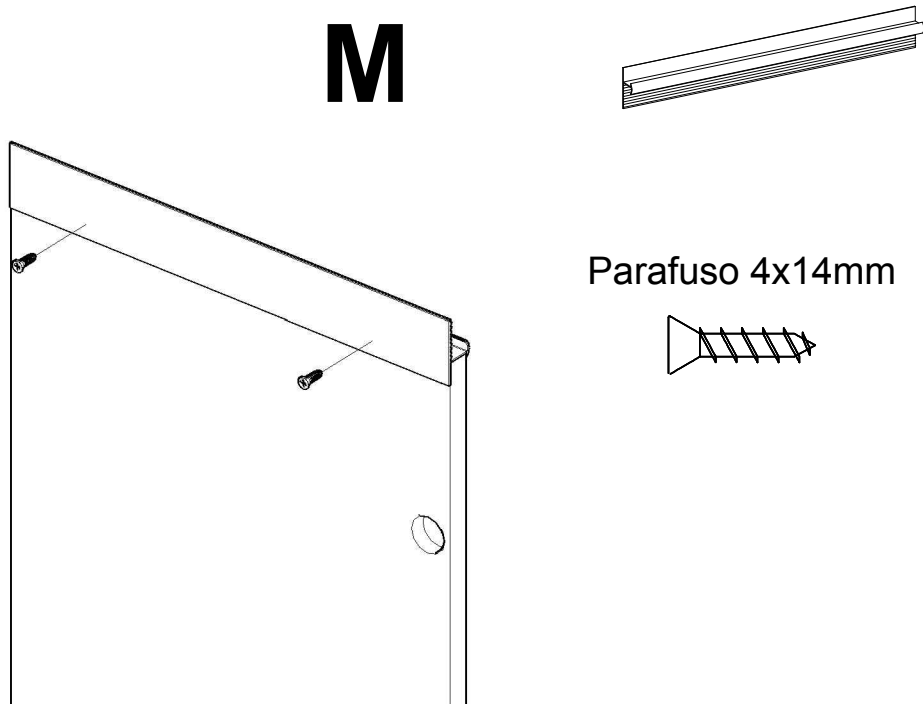
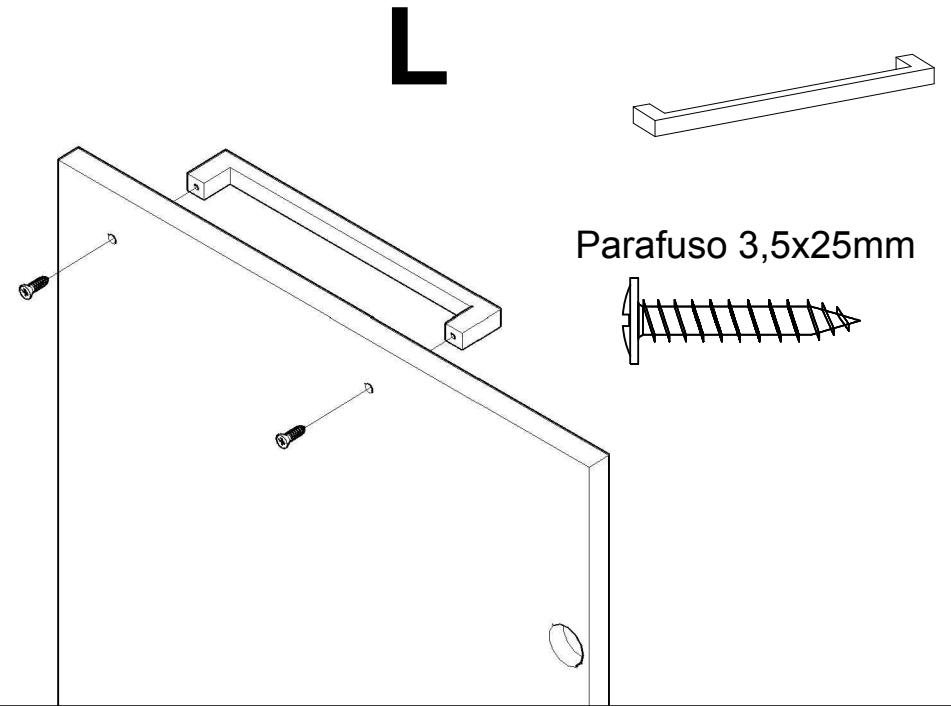
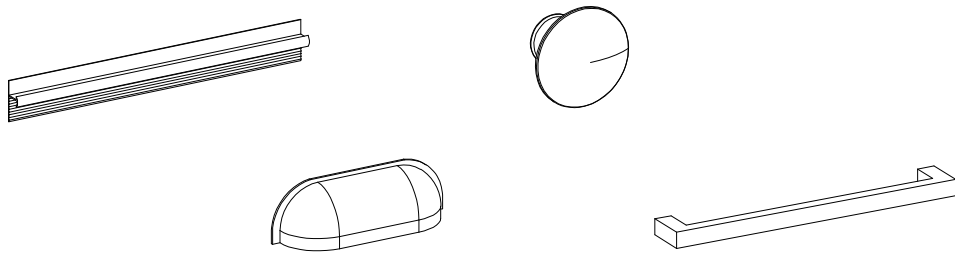

Manual de montagem / Plano de armado

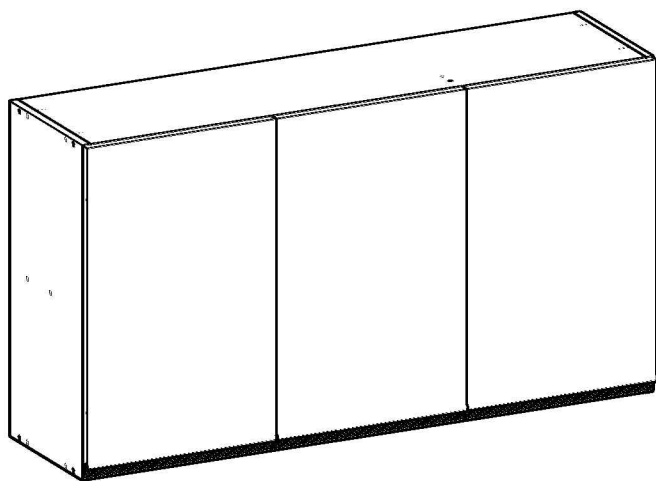

Ref.: 1306M

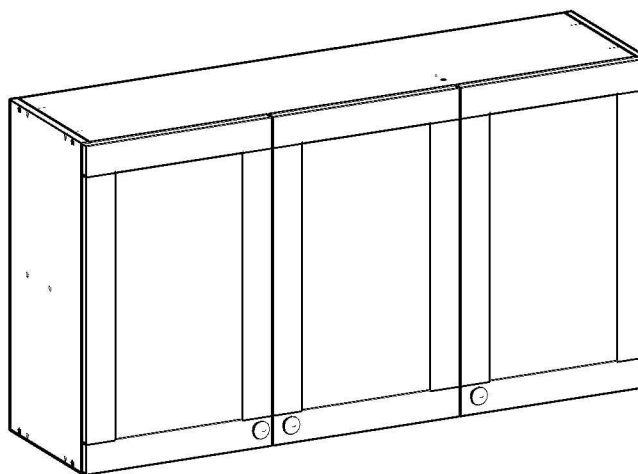

Ref.: 1306P

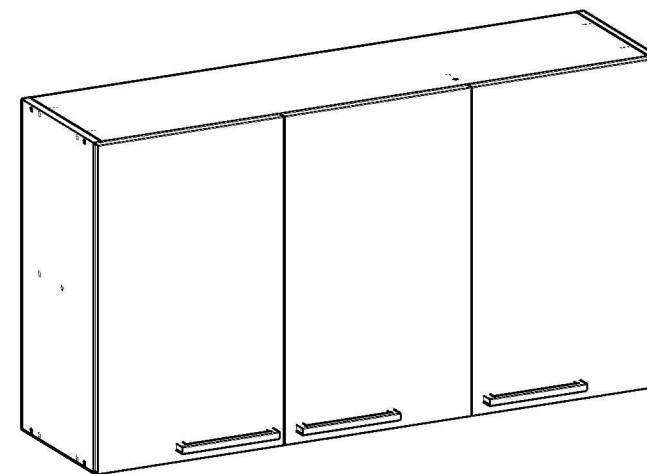

Ref.: 1306L

Parabéns! Você comprou um produto de excelente qualidade, fabricado com chapa de madeira de MDP ou MDF, extraída de florestas renováveis. Possui alta resistência e design atual.

Felicitaciones! Usted compró a un producto de excelente calidad, fabricado con placa de madera de MDP o MDF, proveniente de florestas renovables. Tiene alta resistencia y diseño actual.

Antes de montar o móvel, leia com atenção o manual de montagem!

Antes de armar el mueble, lea con atención el manual de ensamble!



ATENÇÃO:
ATENCIÓN:

1) Verifique todas as peças antes de começar a montagem.

Verifique todas las partes antes de empezar el armado.

2) Ao começar a montagem, não apoie as peças na parede.

Al empezar el armado, no apoyes las partes en la pared.

3) Ao colocar as peças e ferragens de lado, cuidado para não perde-las.

Al poner las piezas y herrages a parte, cuidado para no dañarlas.

4) O móvel deve ser montado no chão, para isso, use a própria caixa para proteger e não danificar o piso.

El mueble suele ser armando al piso, para eso, use la propia caja para protegerlo y no dañar al piso.

5) Comece a montagem seguindo as instruções passo a passo.

Comience el armado siguiendo la instrucciones paso a paso.

6) É de responsabilidade do montador seguir as intrucões desse manual, que são fundamentais para a estrutura do móvel.

Es de responsabilidad del armador seguir las instrucciones de este manual, que son fundamentales para la estructura del mueble.

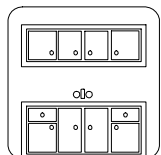

CUIDADOS:
CUIDADOS:

1) A conservação e limpeza deve ser feita com um pano levemente umedecido com água.

La conservación y limpieza debe ser hecha con un trapo levemente humedecido en agua.

2) Não use produtos abrasivos, como saponáceo, detergentes e esponja de aço.

No use productos abrasivos, como saponáceo, detergentes y esponja de acero.

3) Não use cera ou óleo para dar brilho ao móvel.

No use cera o aceites para darle brillo al mueble.



4) Não expor o móvel a interpéries e nem ao calor excessivo.

No exponer el mueble a interperies ni al calor excesivo.

5) Ao terminar a montagem, limpe o ambiente e o móvel.

Al terminar el armado, limpie al ambiente y al mueble.

FERRAMENTAS:
HERRAMIENTAS:

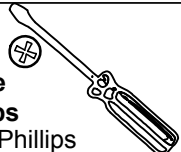
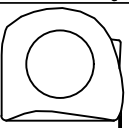





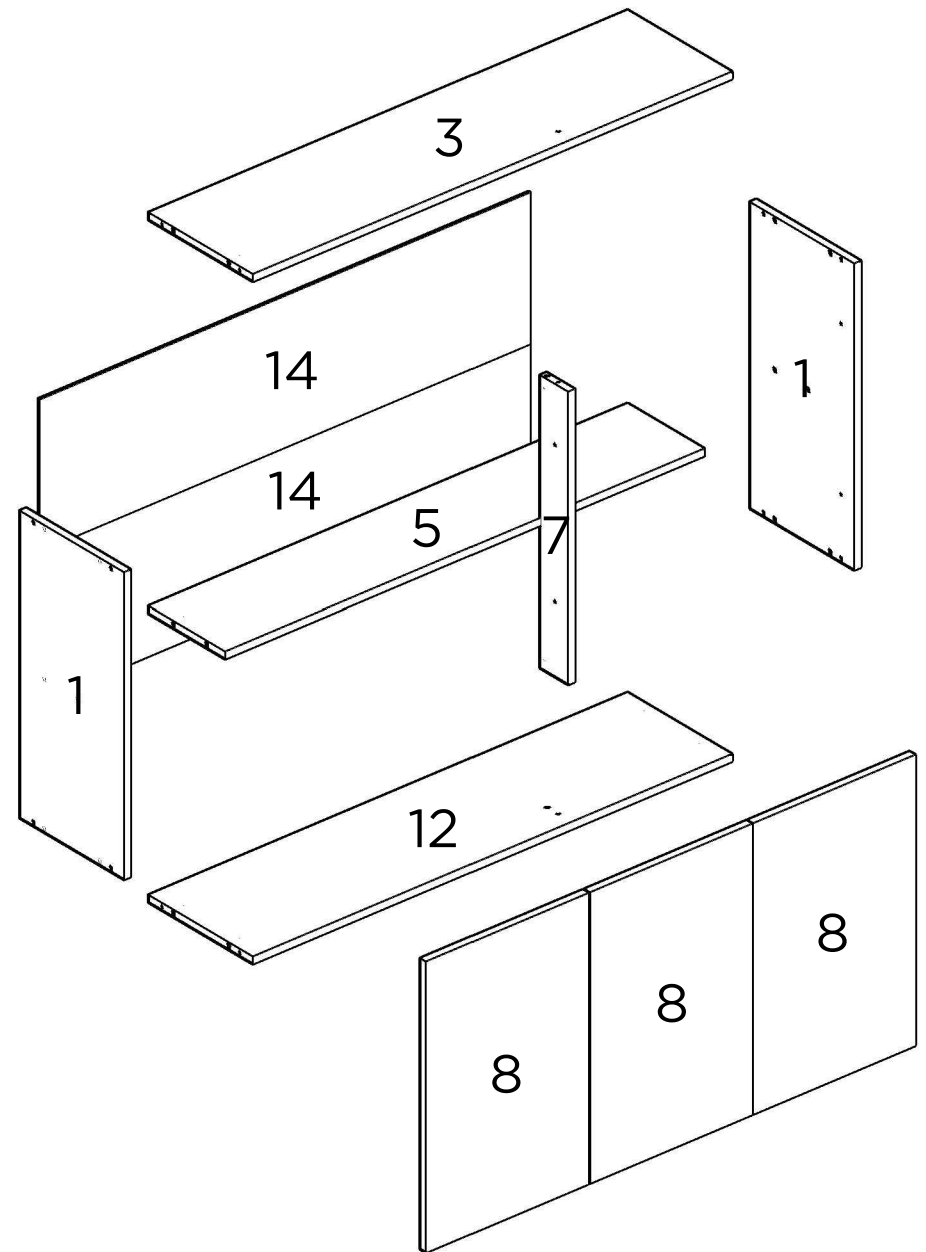

 Parafusadeira Destornillador Eléctrico	 Martelo de borracha Martillo Goma	 Martelo Martillo
 Chave Phillips Llave Phillips	 Trena Cinta métrica	

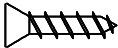
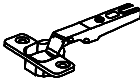
PEÇAS / PIEZAS

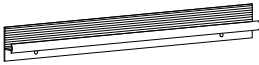
Nº Num	DESCRIÇÃO DESCRIPCIÓN	QTD CANT
1	LATERAL ESQUERDA LATERAL IZQUIERDA	2
3	TAMPO TABLERO	1
5	PRATELEIRA REPISA	1
7	PILASTRA PILAR	1
8	PORTA PUERTA	3
12	BASE BASE	1
14	COSTA TRASERO	2

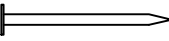

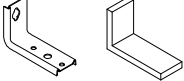
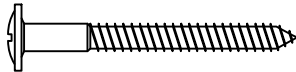
FERRAGENS / HERRAJES

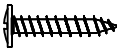
CÓD COD	DESCRIÇÃO DESCRIPCIÓN	QTD CANT
A	 CAVILHA TARUGO	14
B	 PARAFUSO 4X14mm TORNILLO 4X14mm	34
C	 DOBRADIÇA BIZAGRA	6
D	 CALÇO PARA DOBRADIÇA CALZO DE BISAGRA	6
E	 PUXADOR TIRADOR	3
F	 PARAFUSO 3,5X40mm TORNILLO 3,5X40mm	10
G	 PREGO CLAVO	43
H	 GARRA METÁLICA GRAB METALICA	5
I	 SUPORTE DE FIXAÇÃO SOPORTE DE MONTAJE	2
J	 PARAFUSO 5X50mm TORNILLO 5X50mm	2
K	 BUCHA PLÁSTICA CASQUILLO PLÁSTICO	2
L	 PARAFUSO 3.5X25mm TORNILLO 3.5X25mm	2
M	 PARAFUSO 3.5X25mm TORNILLO 3.5X25mm	6

UTILIZE A RÉGUA PARA IDENTIFICAR OS PARAFUSOS
UTILICE LA REGLA PARA IDENTIFICAR LOS TORNILLOS

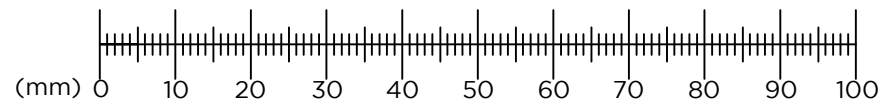

PESO SUPORTADO / PESO SOPORTADO

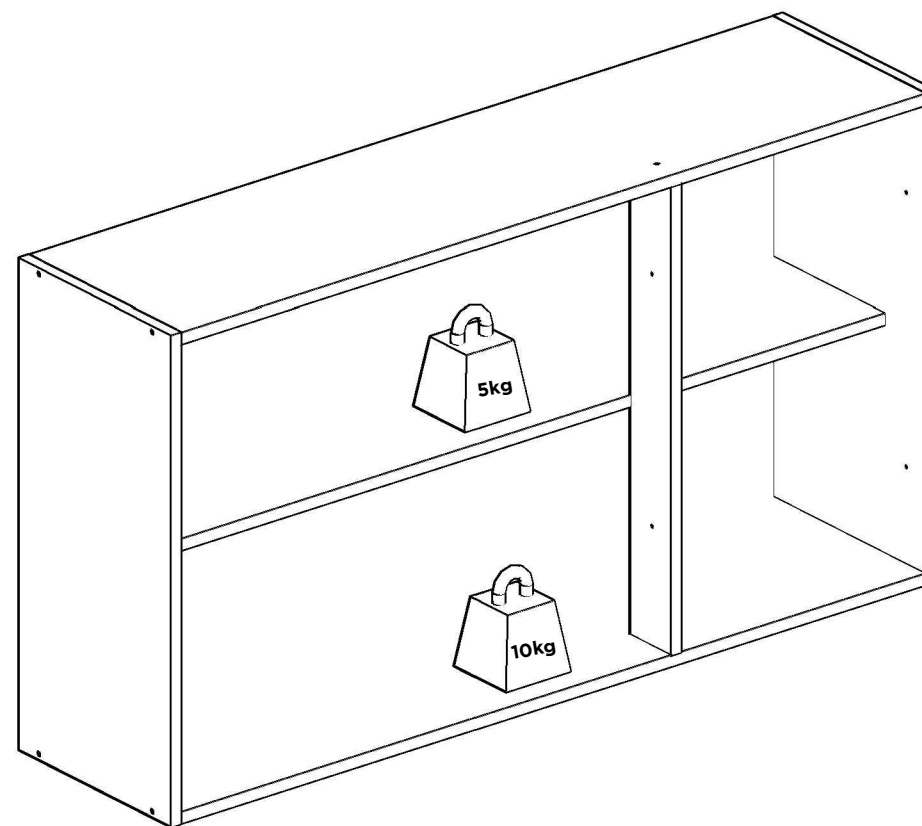

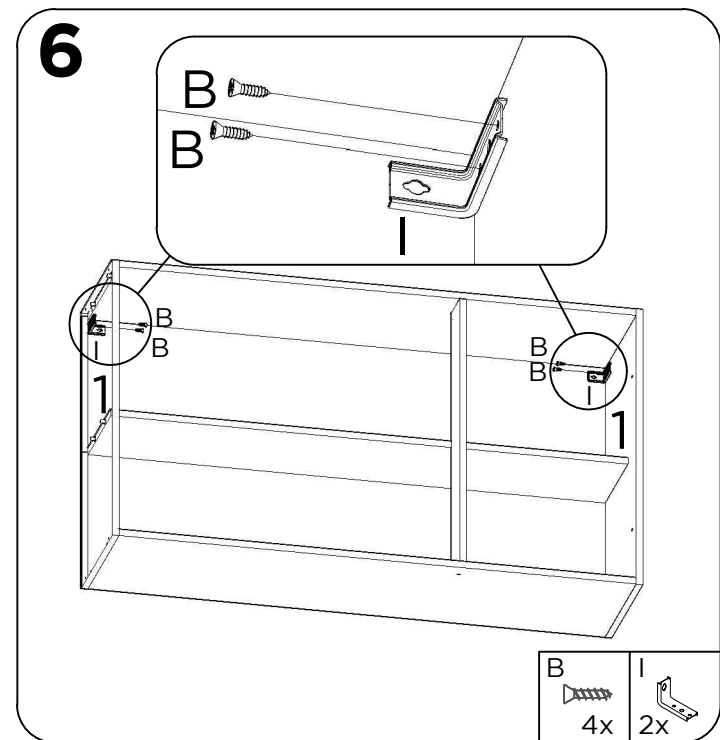
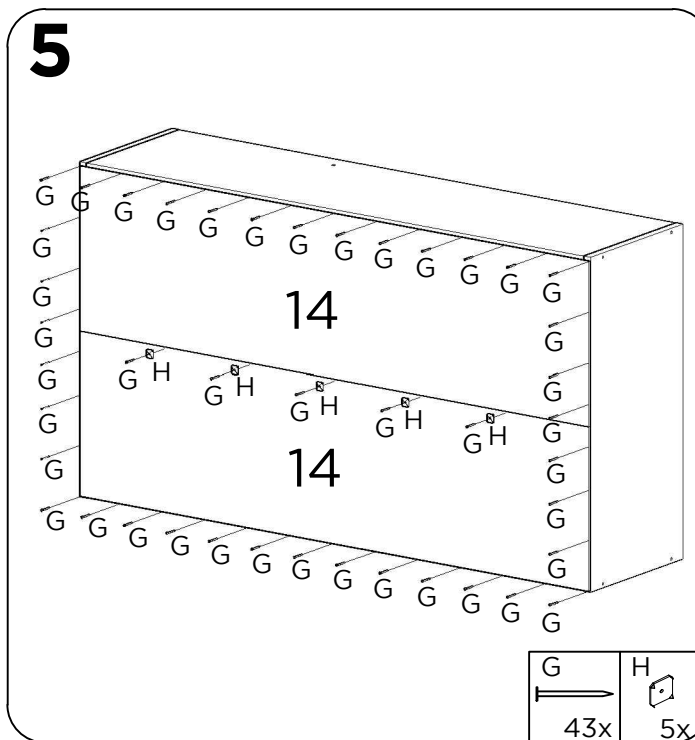
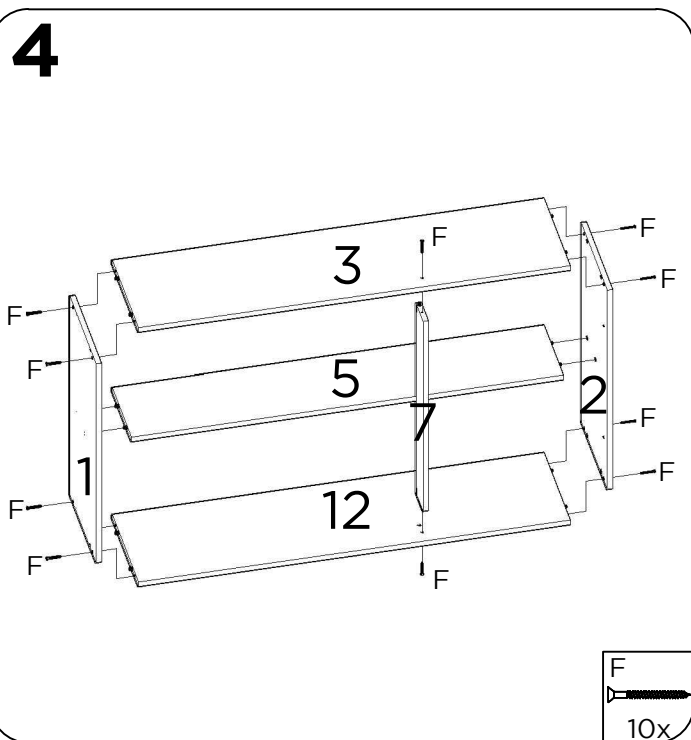
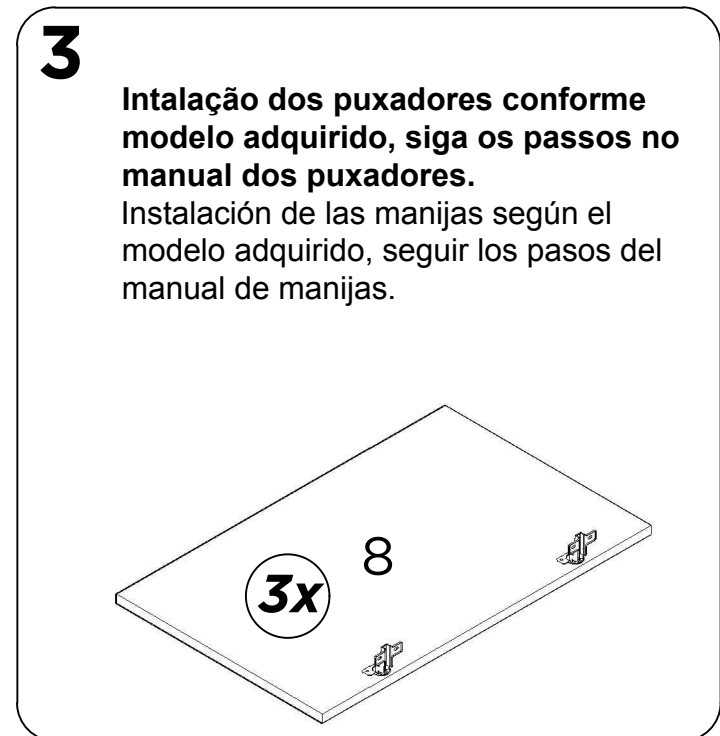
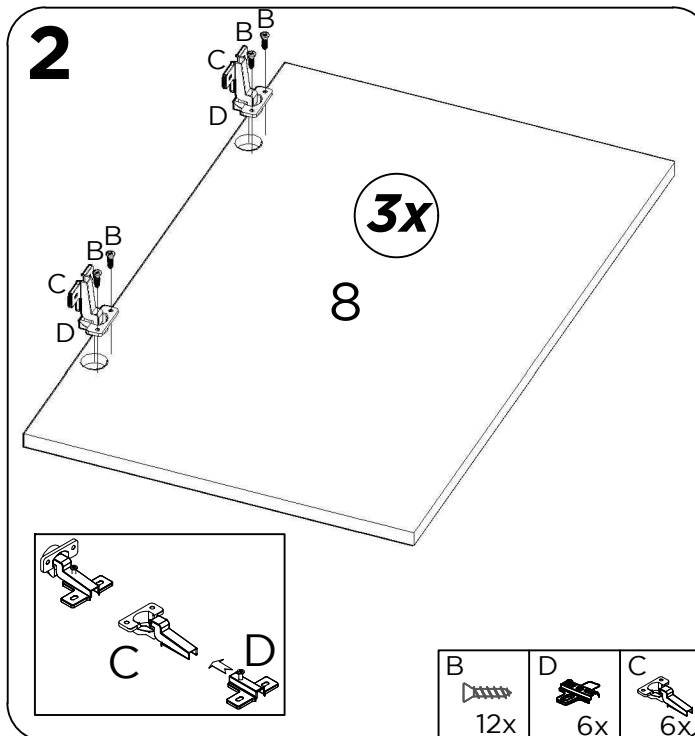
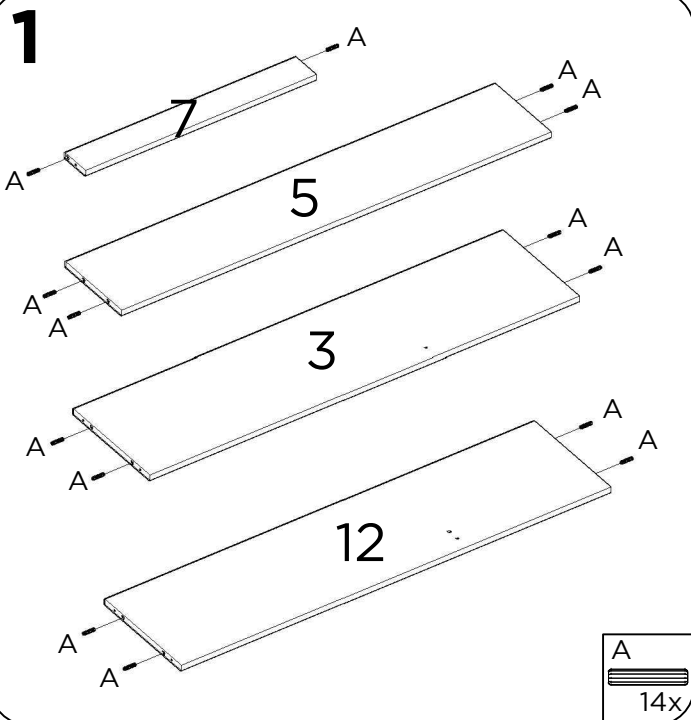

7

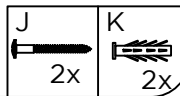
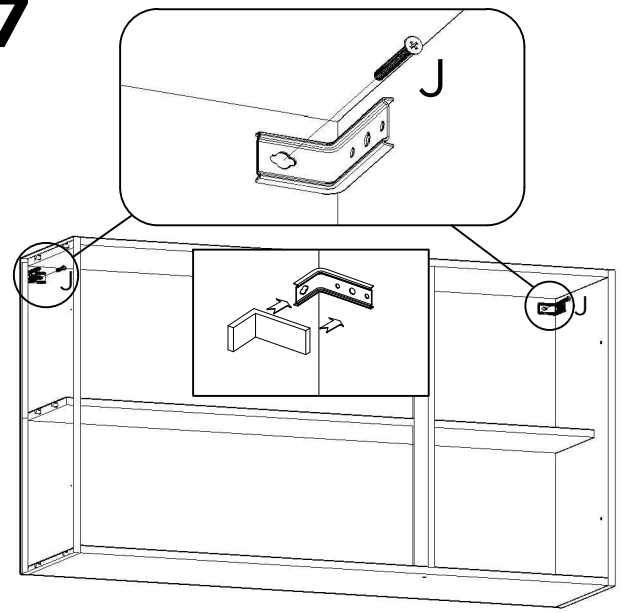

8

União de módulos.
Joining modules.
Unir módulos.

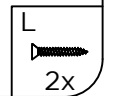
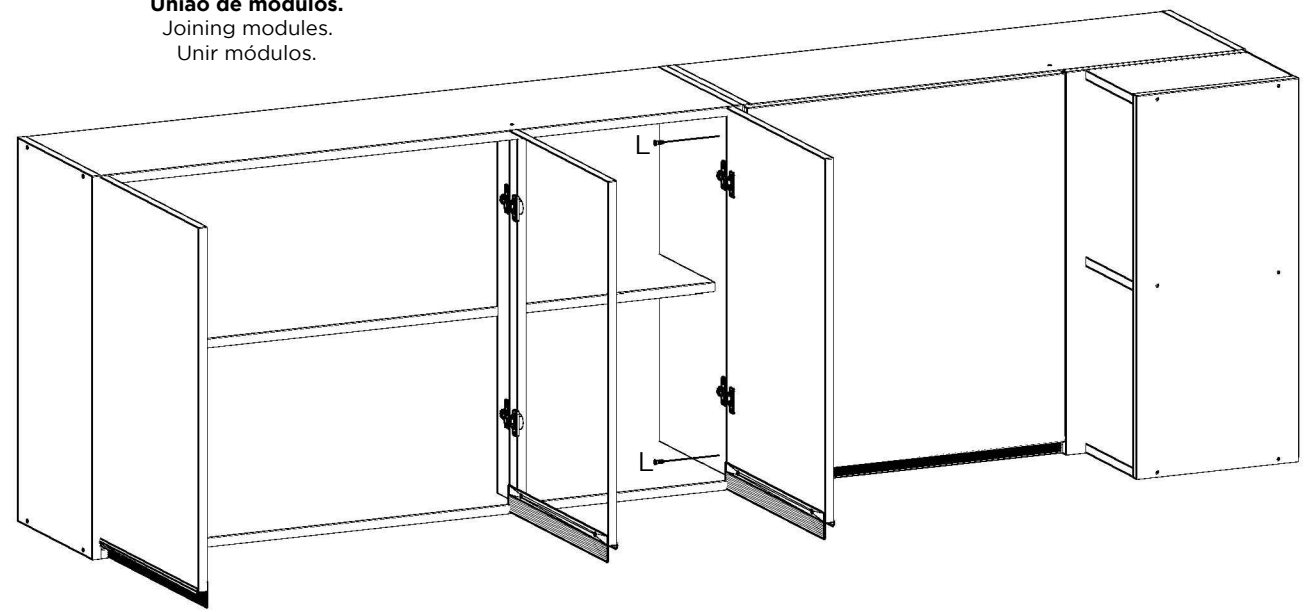

10

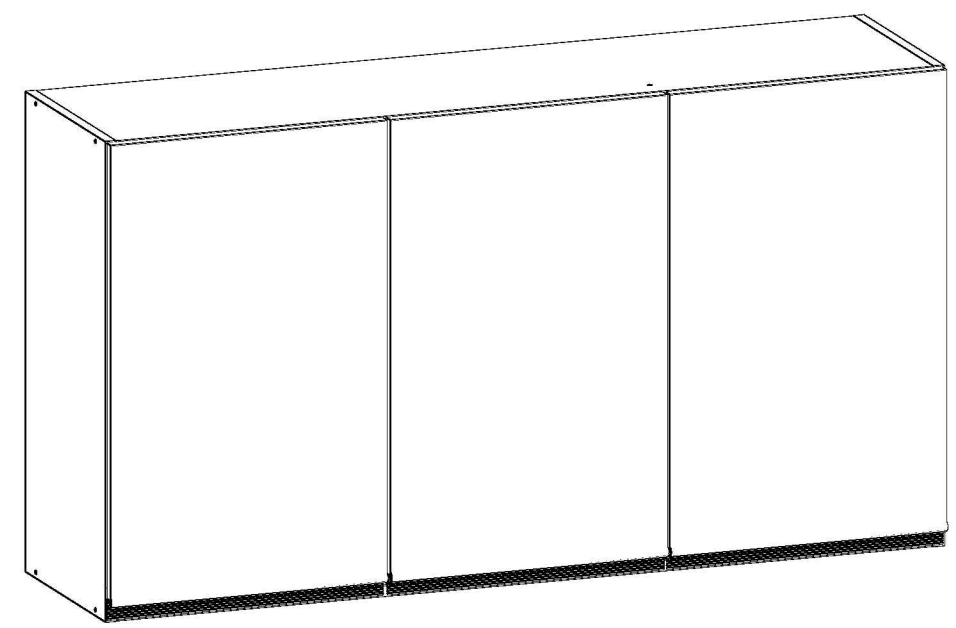
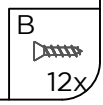
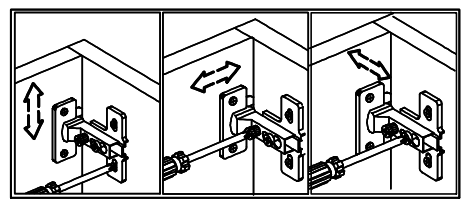
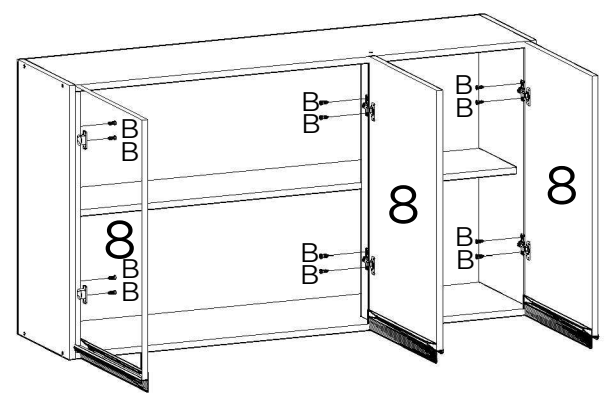

Instalação do puxador. Instalación del tirador

Siga a instrução de montagem do puxador segundo o modelo adquirido. Utilizando as respectivas ferragens.

Siga las instrucciones de montaje del tirador según el modelo adquirido. Usar correctamente la herraje.

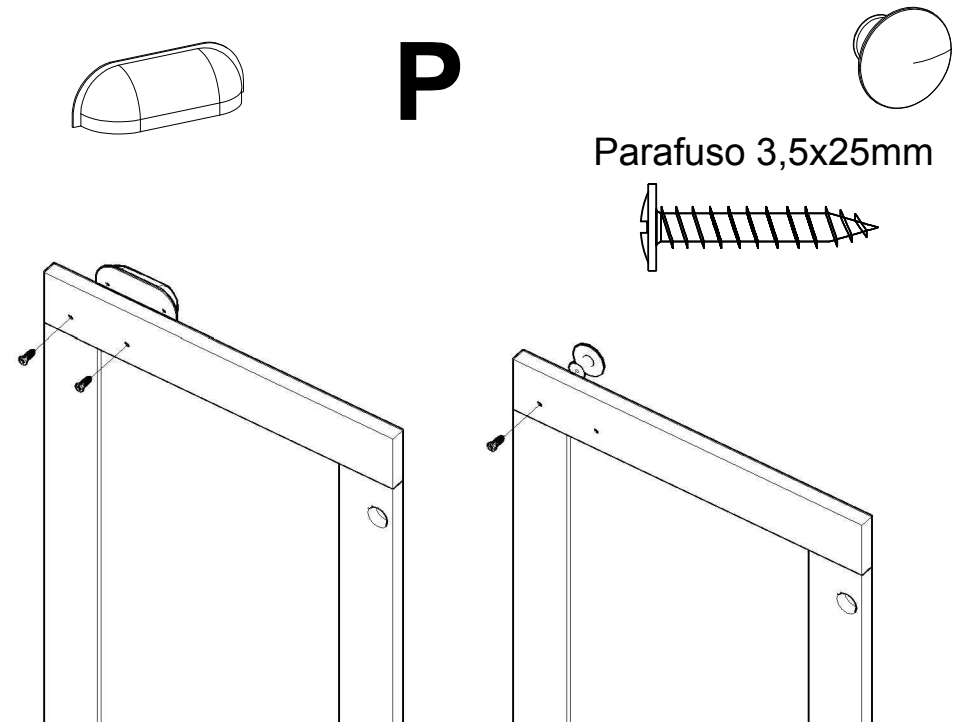
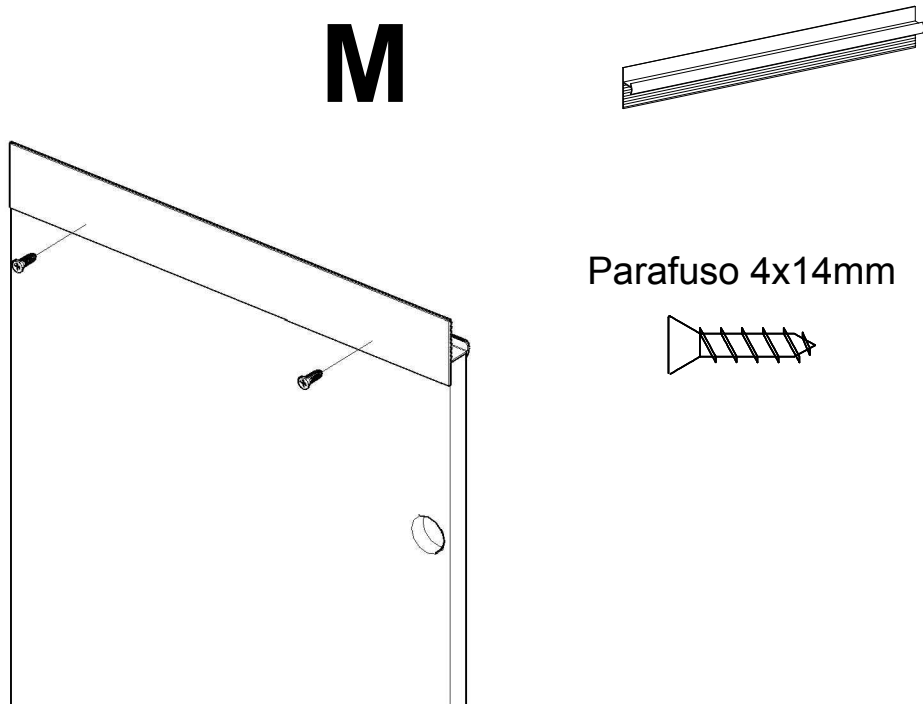
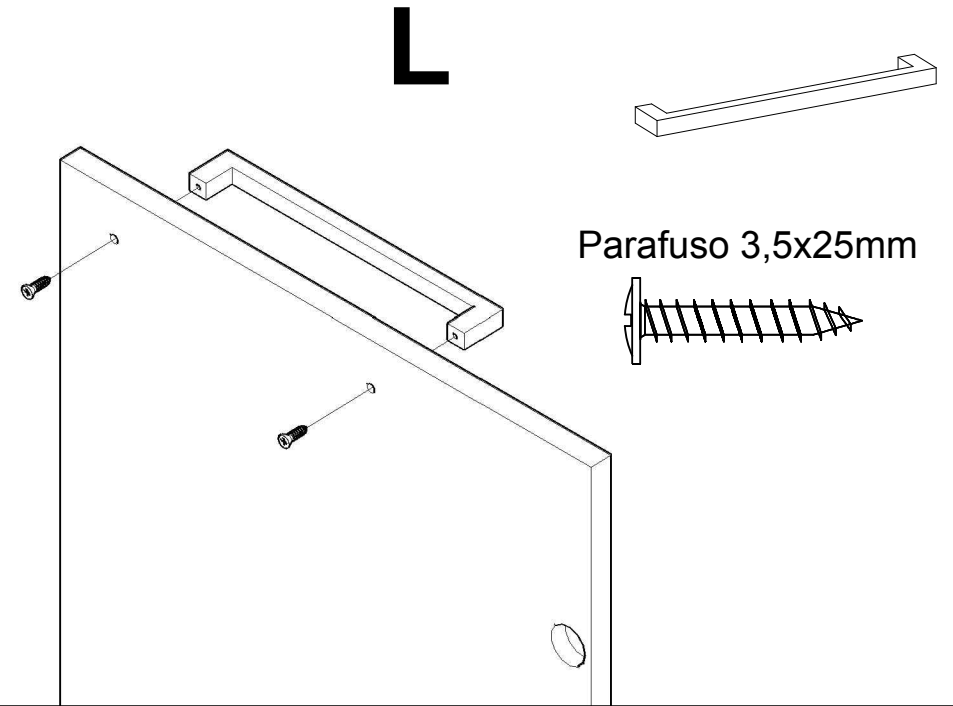
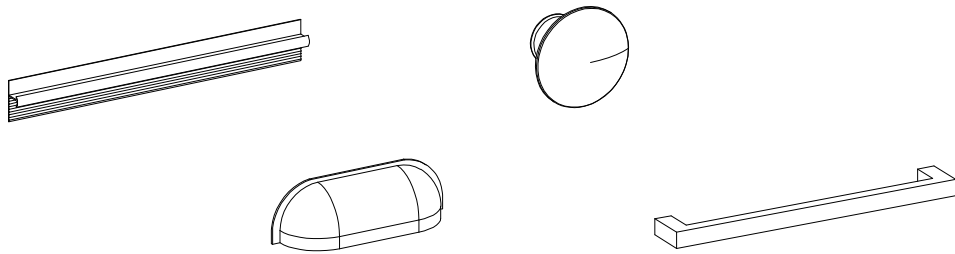

Manual de montagem / Plano de armado

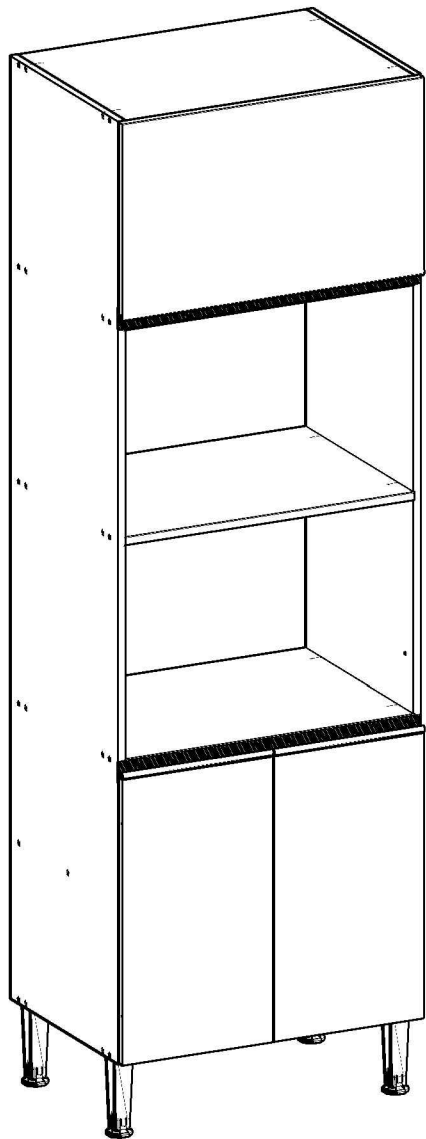

Ref.: 1307M

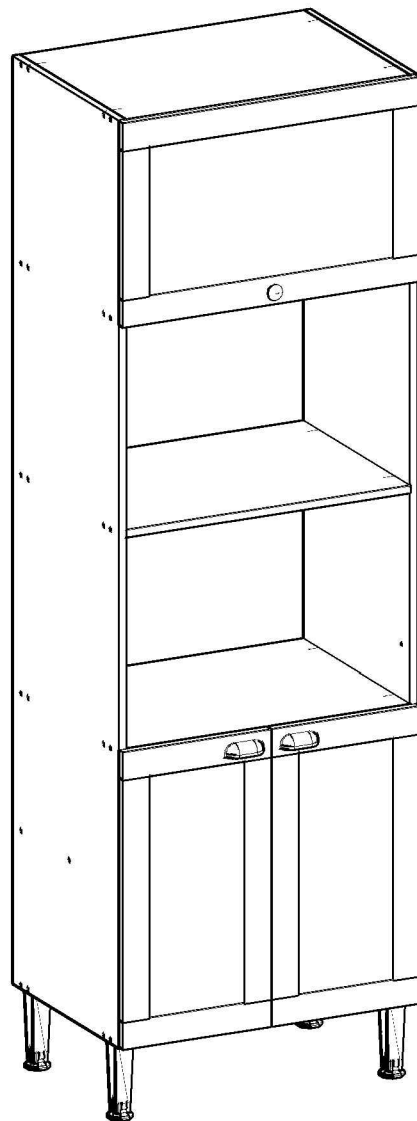

Ref.: 1307P

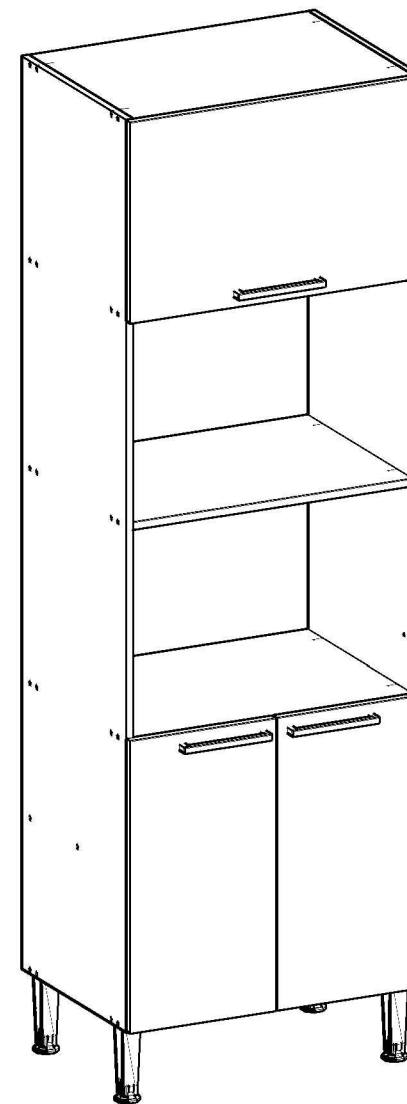

Ref.: 1307L

Parabéns! Você comprou um produto de excelente qualidade, fabricado com chapa de madeira de MDP ou MDF, extraída de florestas renováveis. Possui alta resistência e design atual.

Felicitaciones! Usted compró a un producto de excelente calidad, fabricado con placa de madera de MDP o MDF, proveniente de florestas renovables. Tiene alta resistencia y diseño actual.

Antes de montar o móvel, leia com atenção o manual de montagem!

Antes de armar el mueble, lea con atención el manual de ensamble!



ATENÇÃO:
ATENCIÓN:

1) Verifique todas as peças antes de começar a montagem.

Verifique todas las partes antes de empezar el armado.

2) Ao começar a montagem, não apoie as peças na parede.

Al empezar el armado, no apoyes las partes en la pared.

3) Ao colocar as peças e ferragens de lado, cuidado para não perde-las.

Al poner las piezas y herrages a parte, cuidado para no dañarlas.

4) O móvel deve ser montado no chão, para isso, use a própria caixa para proteger e não danificar o piso.

El mueble suele ser armando al piso, para eso, use la propia caja para protegerlo y no dañar al piso.

5) Comece a montagem seguindo as instruções passo a passo.

Comience el armado siguiendo la instrucciones paso a paso.

6) É de responsabilidade do montador seguir as intrucões desse manual, que são fundamentais para a estrutura do móvel.

Es de responsabilidad del armador seguir las instrucciones de este manual, que son fundamentales para la estructura del mueble.

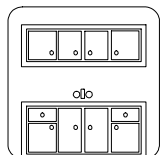

CUIDADOS:
CUIDADOS:

1) A conservação e limpeza deve ser feita com um pano levemente umedecido com água.

La conservación y limpieza debe ser hecha con un trapo levemente humedecido en agua.

2) Não use produtos abrasivos, como saponáceo, detergentes e esponja de aço.

No use productos abrasivos, como saponáceo, detergentes y esponja de acero.

3) Não use cera ou óleo para dar brilho ao móvel.

No use cera o aceites para darle brillo al mueble.



4) Não expor o móvel a interpéries e nem ao calor excessivo.

No exponer el mueble a interperies ni al calor excesivo.

5) Ao terminar a montagem, limpe o ambiente e o móvel.

Al terminar el armado, limpie al ambiente y al mueble.

FERRAMENTAS:
HERRAMIENTAS:

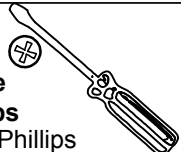
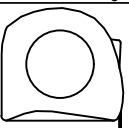





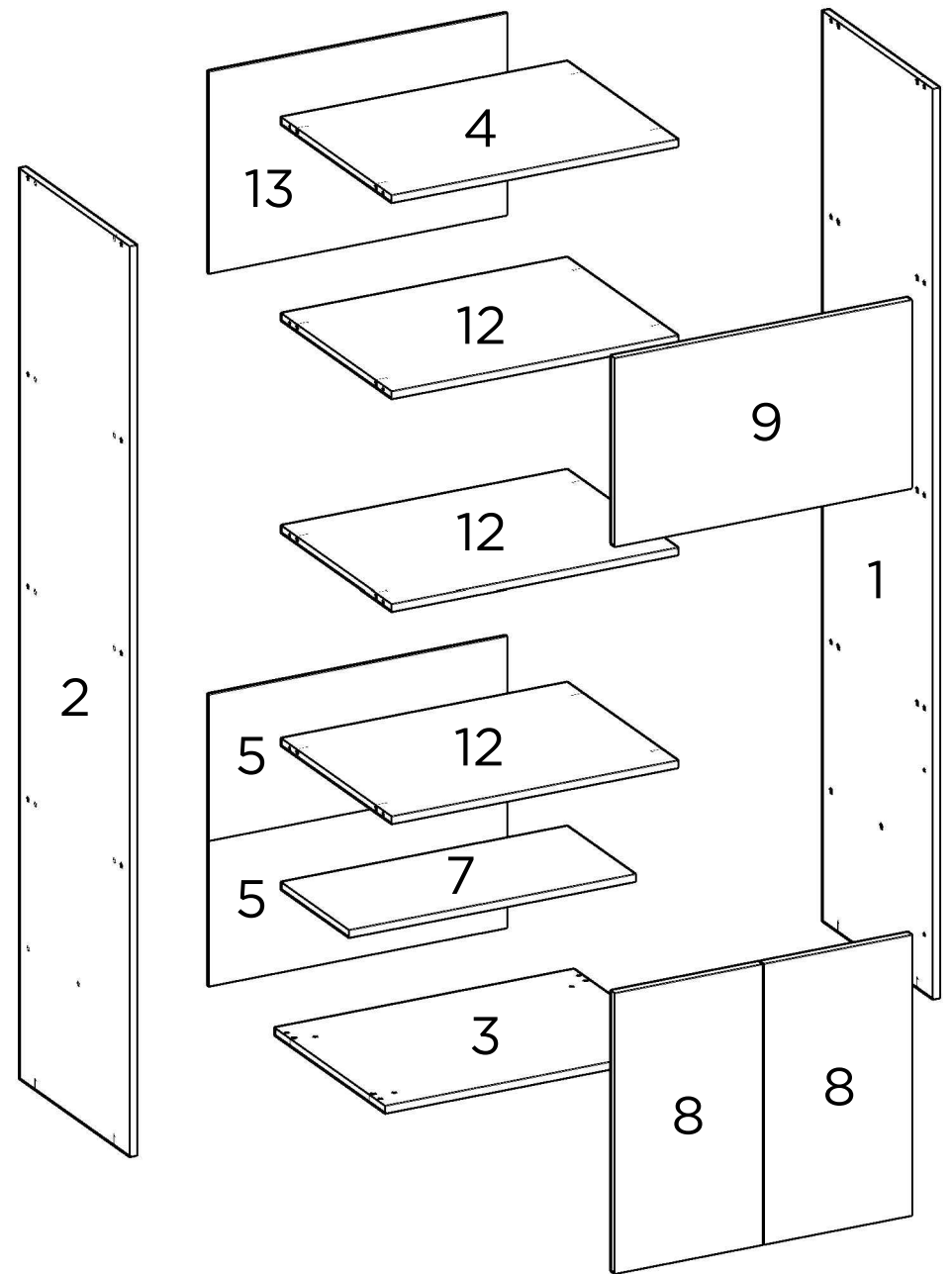

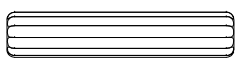

 Parafusadeira Destornillador Eléctrico	 Martelo de borracha Martillo Goma	 Martelo Martillo
 Chave Phillips Llave Phillips	 Trena Cinta métrica	

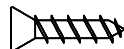
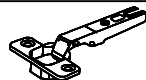
PEÇAS / PARTS / PIEZAS

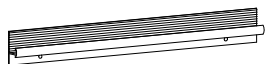
Nº No Num	DESCRIÇÃO DESCRIPTION DESCRIPCIÓN	QTD QTY CANT
1	LATERAL DIREITA RIGHT SIDE PANEL LATERAL DERECHA	1
2	LATERAL ESQUERDA LEFT SIDE PANEL LATERAL IZQUIERDA	1
3	BASE BOTTOM BASE	1
4	TAMPO TOP TABLERO	1
5	COSTA INFERIOR LOWER BACK PANEL TRASERO INFERIOR	2
7	PRATELEIRA PLATE PANEL REPISA	1
8	PORTA DOOR PUERTA	2
9	PORTA BASCULANTE TILTING DOOR PUERTA BASCULANTE	1
12	BASE / PRATELEIRA BOTTOM PANEL / PLATE PANEL BASE / REPISA	3
13	COSTA SUPERIOR UPPER BACK PANEL TRASERO SUPERIOR	1

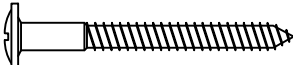
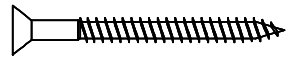
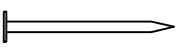
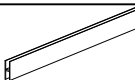

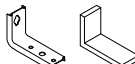
FERRAGENS / HARDWARE / HERRAJES

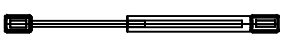
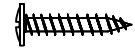
CÓD CODE COD	DESCRIÇÃO DESCRIPTION DESCRIPCIÓN	QTD QTY CANT
A	 CAVILHA WOODEN DOWEL TARUGO	20
B	 SUPORTE DE PRATELEIRA SHELF SUPPORT SOPORTE DE ESTANTES	4
C	 PARAFUSO 4X14mm SCREW 4X14mm TORNILLO 4X14mm	33
D	 DOBRADIÇA HINGE BIZAGRA	6
E	 CALÇO PARA DOBRADIÇA HINGE SHED CALZO DE BISAGRA	6
F	 PUXADOR PULLER TIRADOR	3
G	 PÉ LEG PATA	4
H	 PARAFUSO 5X50mm SCREW 5X50mm TORNILLO 5X50mm	5
I	 PARAFUSO 3,5X40mm SCREW 3,5X40mm TORNILLO 3,5X40mm	20
J	 PREGO NAIL CLAVO	56
K	 PERFIL I PROFILE I PERFIL I	1
L	 PARAFUSO 3.5X25mm SCREW 3.5X25mm TORNILLO 3.5X25mm	2
M	 SUPORTE DE FIXAÇÃO MOUNTING SUPPORT SOPORTE DE MONTAJE	1
N	 BUCHA PLÁSTICA PLASTIC BUSHING CASQUILLO PLÁSTICO	1
O	 PISTÃO PISTON PISTÓN	1
P	 PARAFUSO 3.5X25mm SCREW 3.5X25mm TORNILLO 3.5X25mm	6

UTILIZE A RÉGUA PARA IDENTIFICAR OS PARAFUSOS
USE THE RULER TO IDENTIFY THE SCREWS
UTILICE LA REGLA PARA IDENTIFICAR LOS TORNILLOS



PESO SUPORTADO / WEIGHT SUPPORTED / PESO SOPORTADO

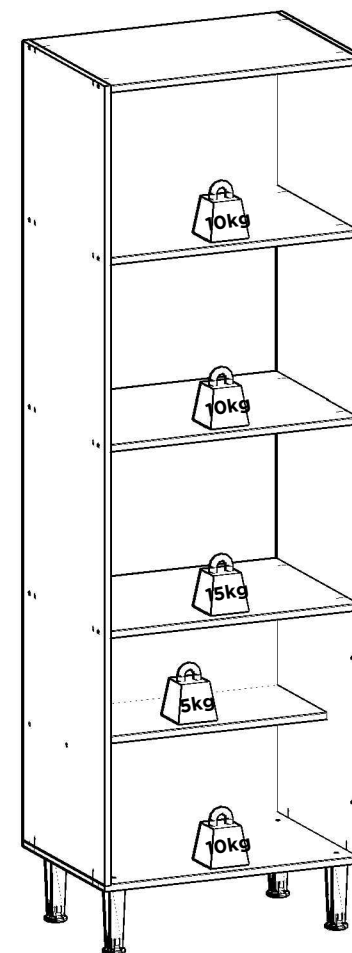

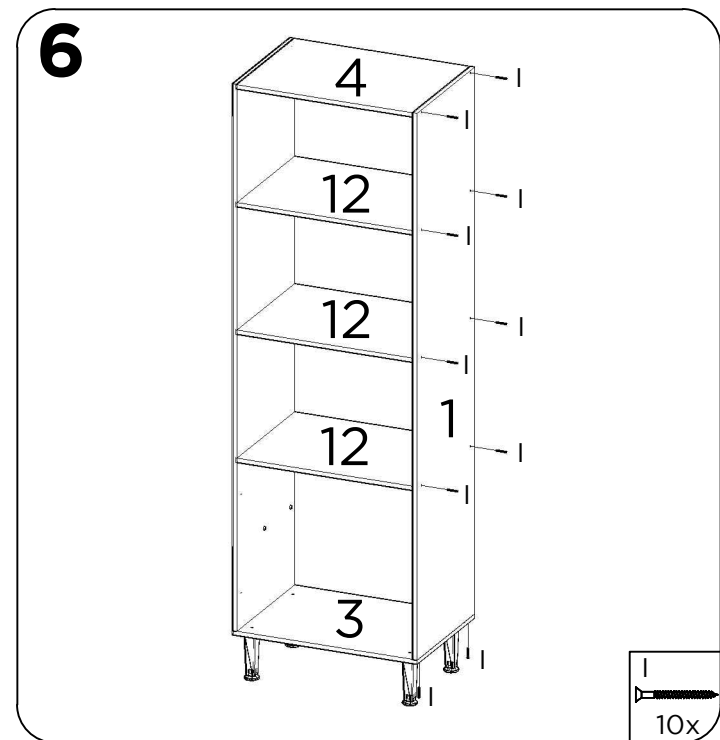
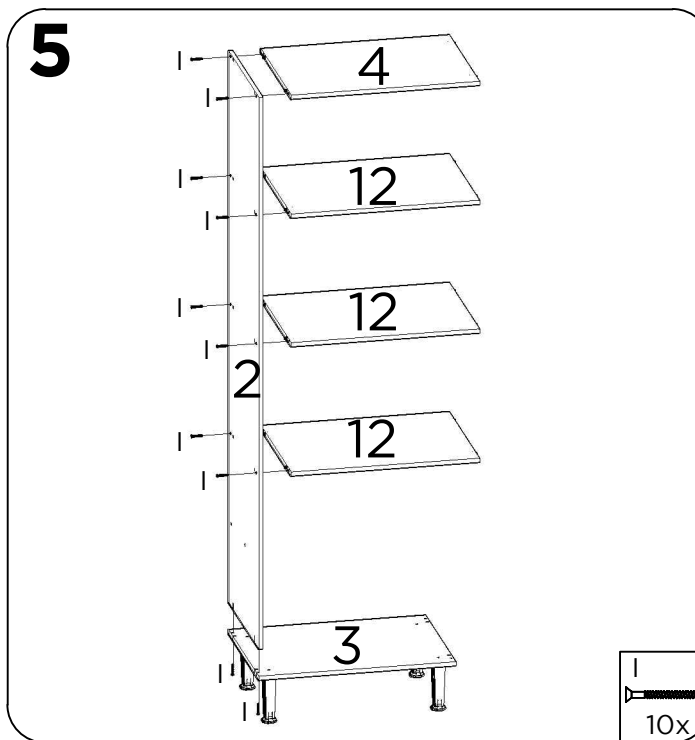
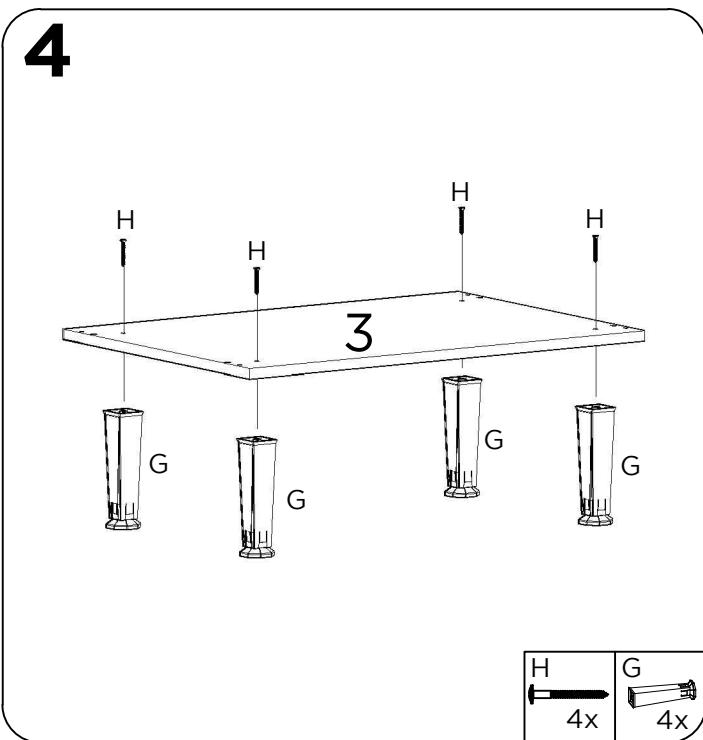
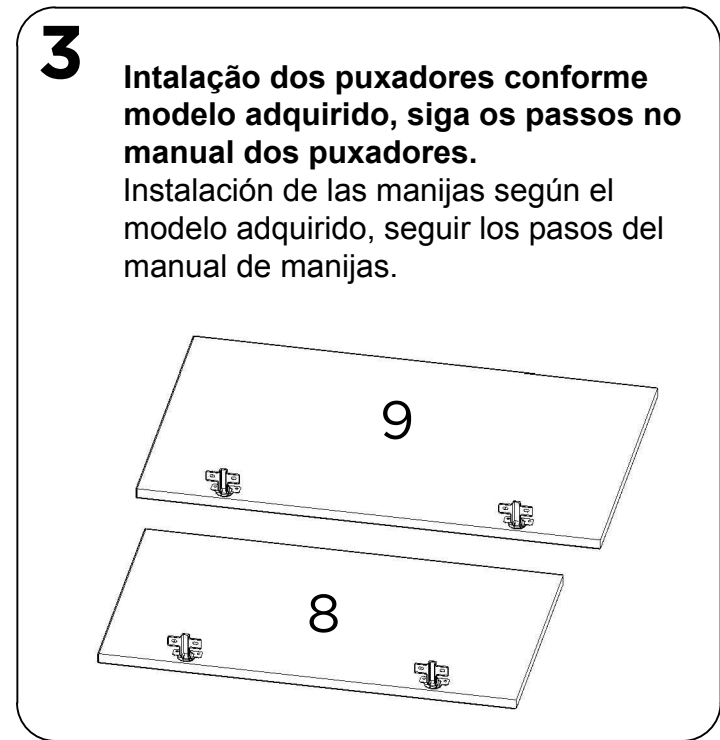
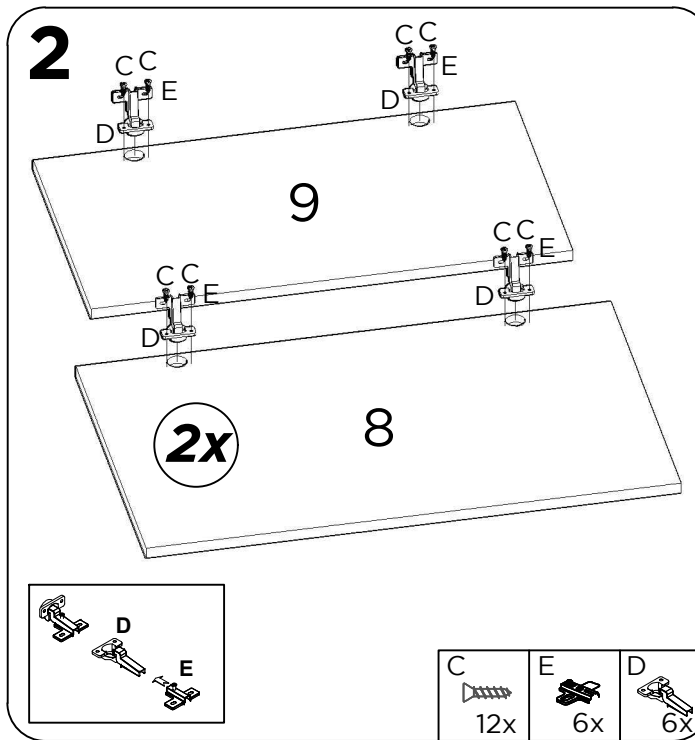
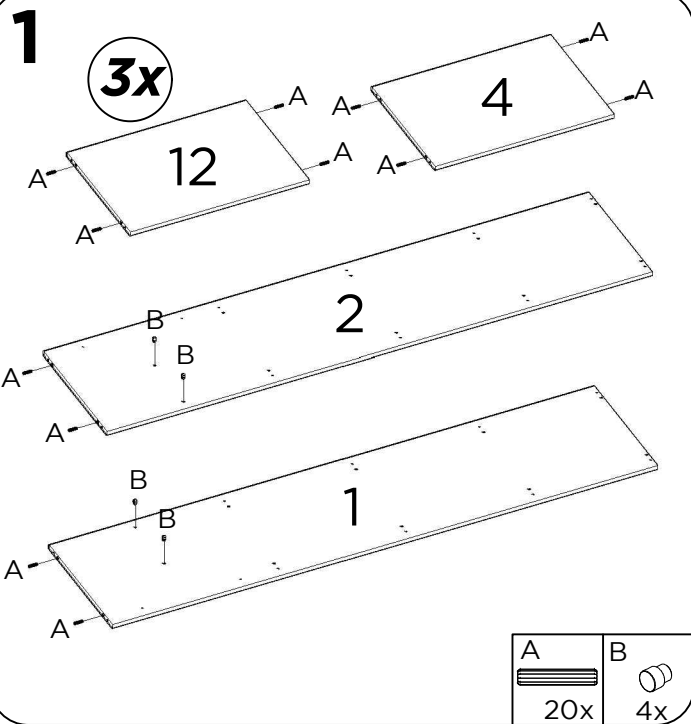

7

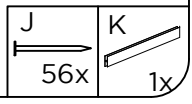
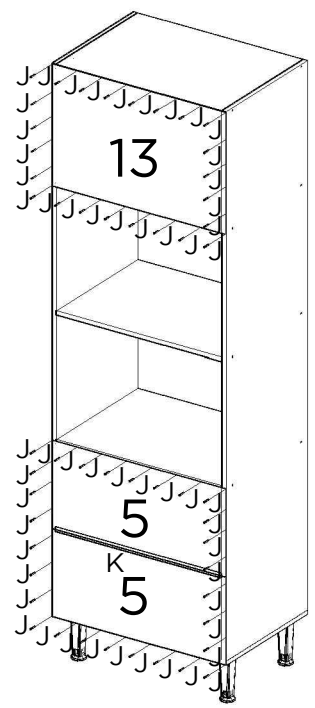
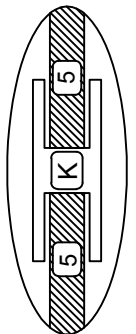

8

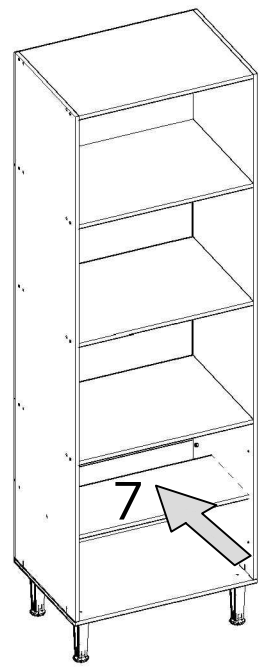

9

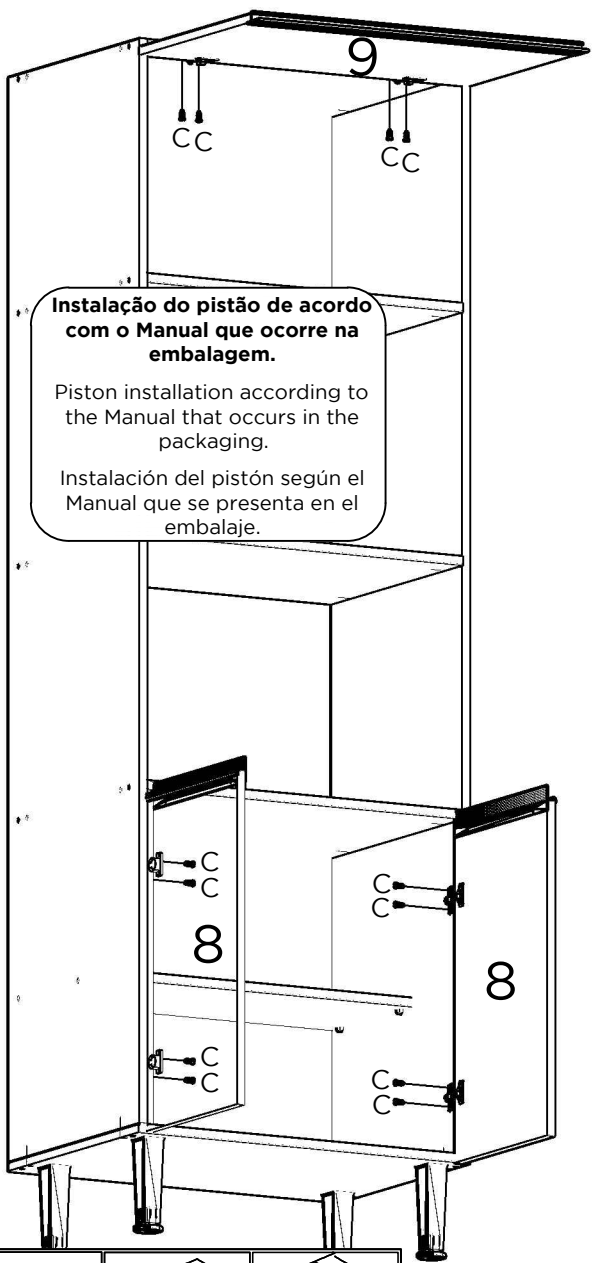

Instalação do pistão de acordo com o Manual que ocorre na embalagem.

Piston installation according to the Manual that occurs in the packaging.

Instalación del pistón según el Manual que se presenta en el embalaje.

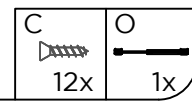
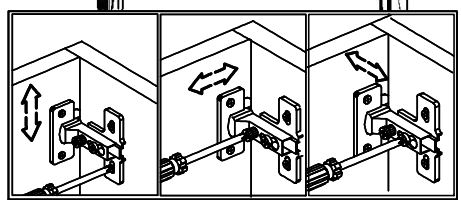

10

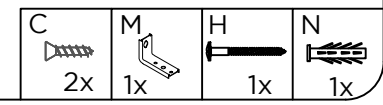
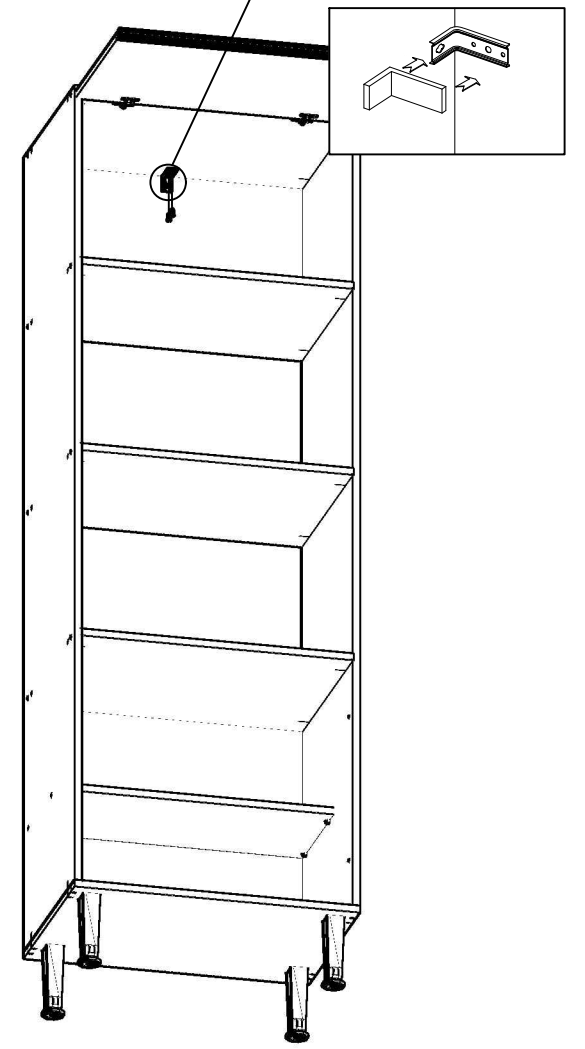
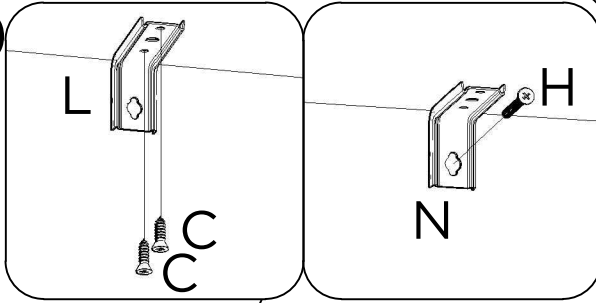

11

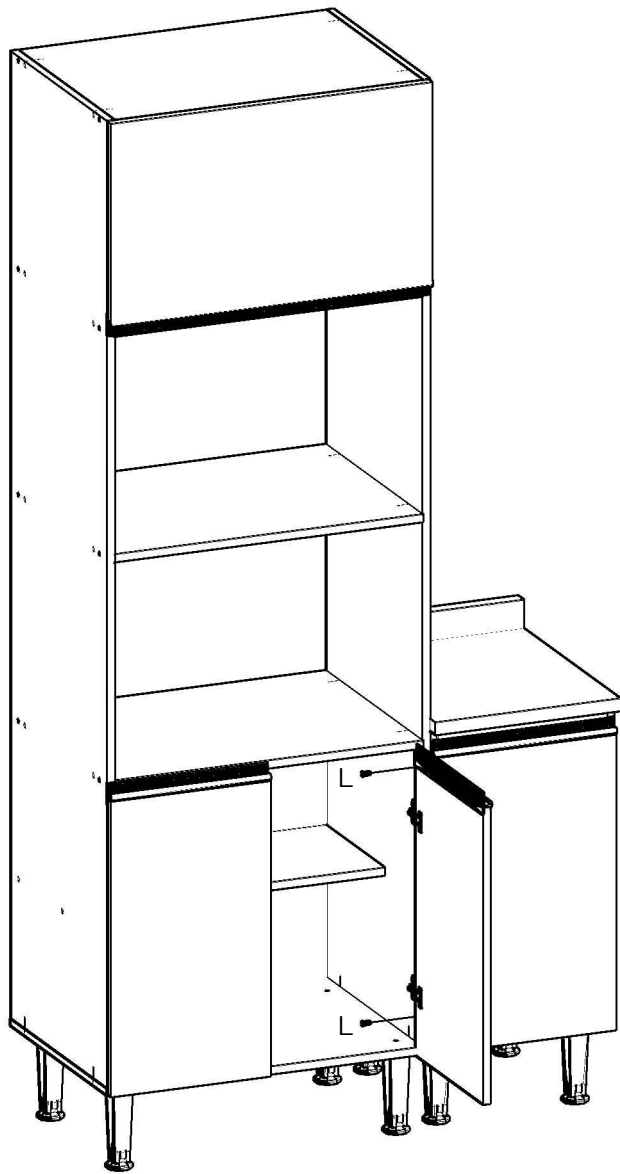

L
2x

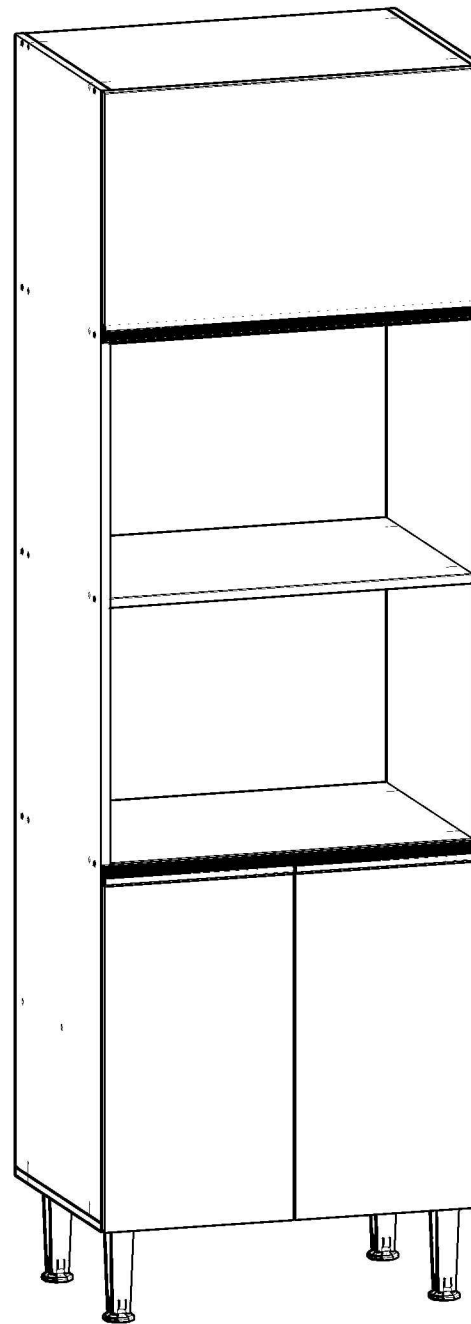

Instalação do puxador. Instalación del tirador

Siga a instrução de montagem do puxador segundo o modelo adquirido. Utilizando as respectivas ferragens.

Siga las instrucciones de montaje del tirador según el modelo adquirido. Usar correctamente la herraje.

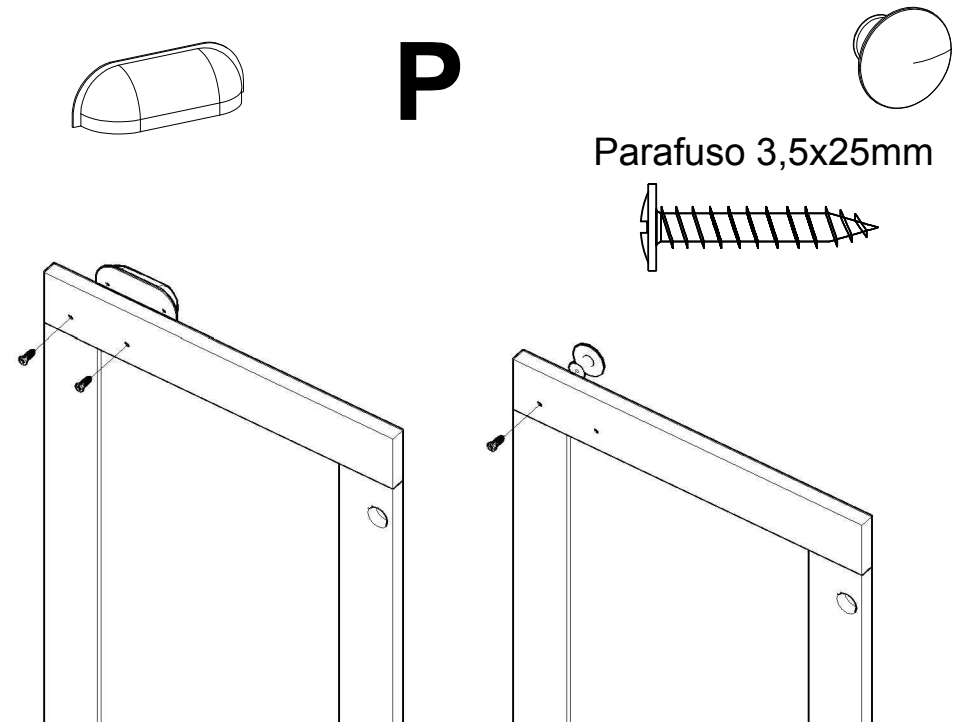
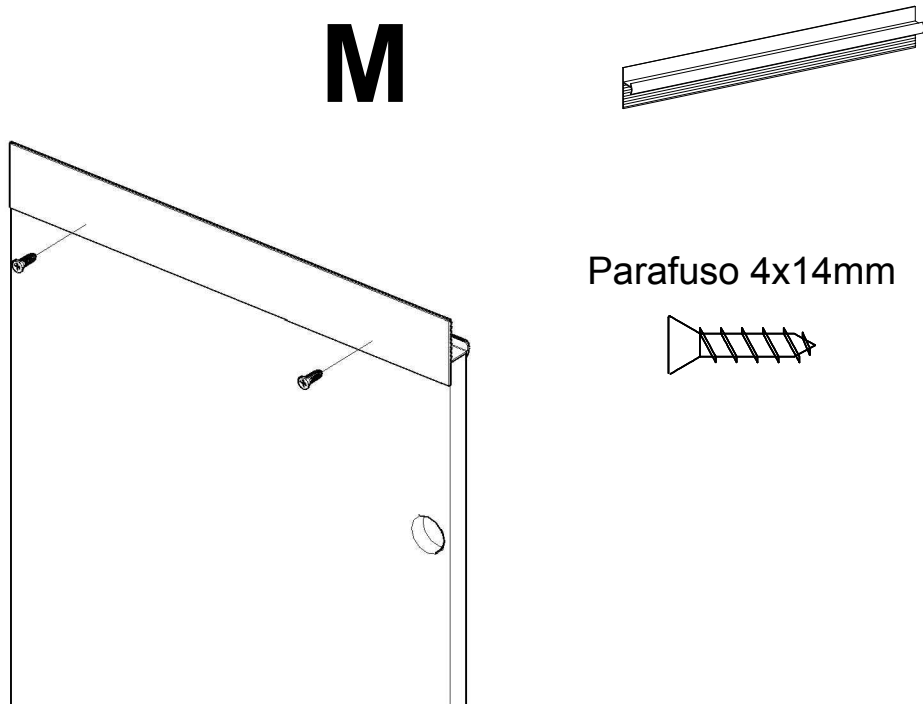
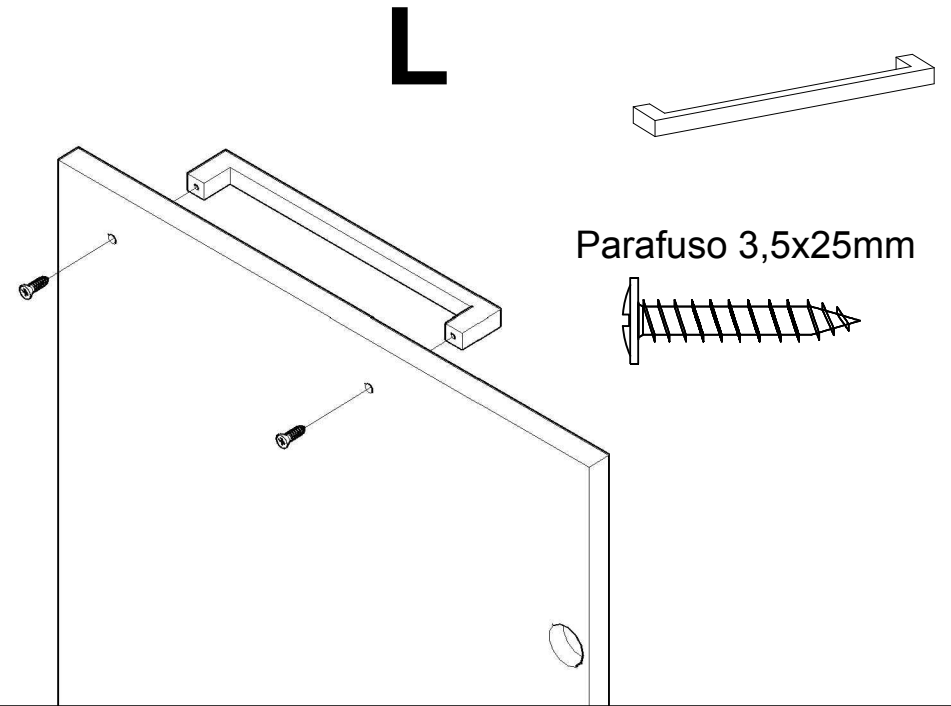
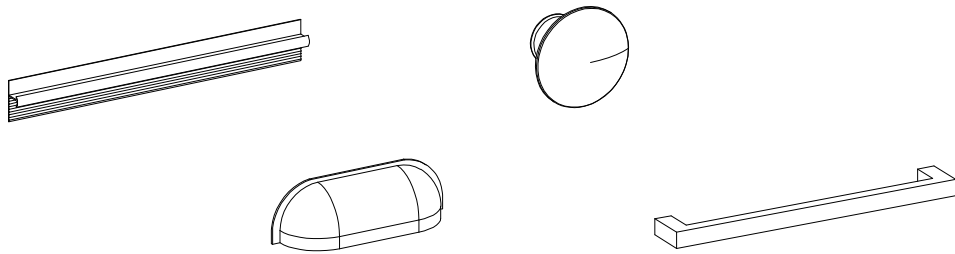

Manual de montagem / Plano de armado

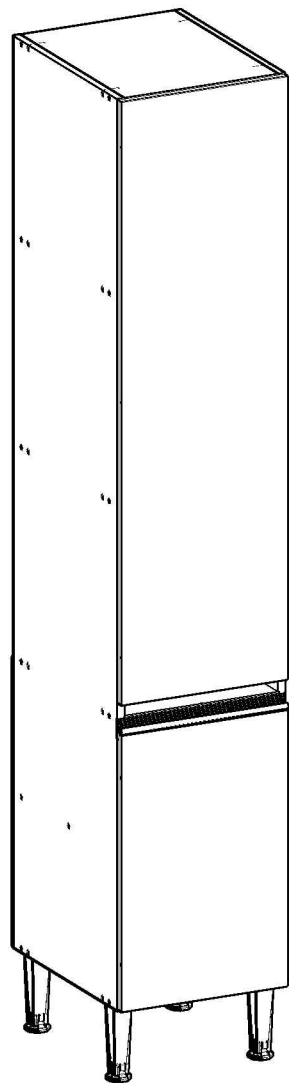

Ref.: 1308M

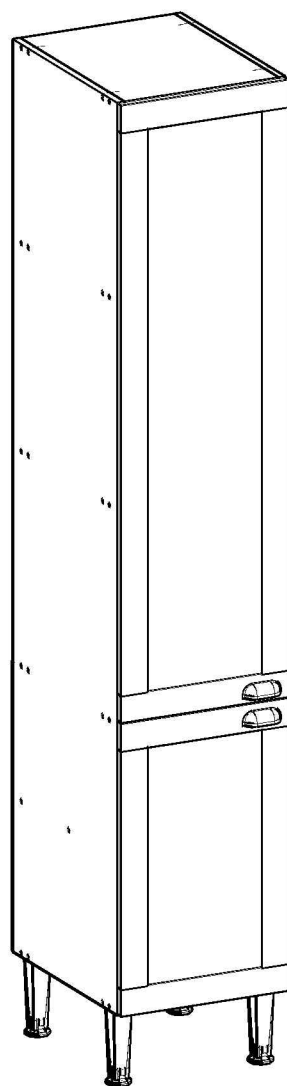

Ref.: 1308P

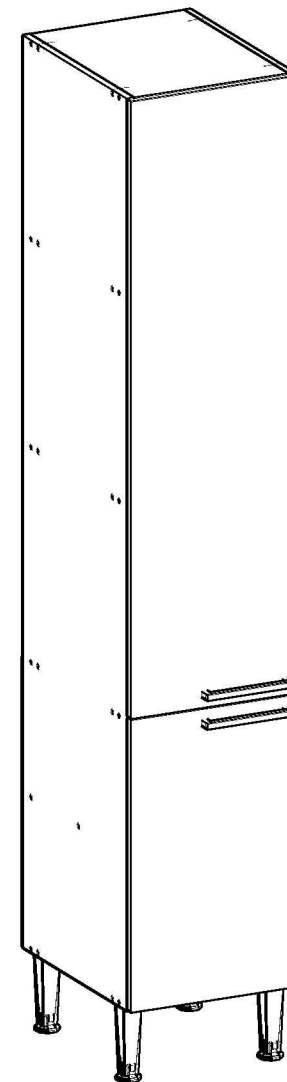

Ref.: 1308L

Parabéns! Você comprou um produto de excelente qualidade, fabricado com chapa de madeira de MDP ou MDF, extraída de florestas renováveis. Possui alta resistência e design atual.

Felicitaciones! Usted compró a un producto de excelente calidad, fabricado con placa de madera de MDP o MDF, proveniente de florestas renovables. Tiene alta resistencia y diseño actual.

Antes de montar o móvel, leia com atenção o manual de montagem!

Antes de armar el mueble, lea con atención el manual de ensamble!



ATENÇÃO:
ATENCIÓN:

1) Verifique todas as peças antes de começar a montagem.

Verifique todas las partes antes de empezar el armado.

2) Ao começar a montagem, não apoie as peças na parede.

Al empezar el armado, no apoyes las partes en la pared.

3) Ao colocar as peças e ferragens de lado, cuidado para não perde-las.

Al poner las piezas y herrages a parte, cuidado para no dañarlas.

4) O móvel deve ser montado no chão, para isso, use a própria caixa para proteger e não danificar o piso.

El mueble suele ser armando al piso, para eso, use la propia caja para protegerlo y no dañar al piso.

5) Comece a montagem seguindo as instruções passo a passo.

Comience el armado siguiendo la instrucciones paso a paso.

6) É de responsabilidade do montador seguir as intrucões desse manual, que são fundamentais para a estrutura do móvel.

Es de responsabilidad del armador seguir las instrucciones de este manual, que son fundamentales para la estructura del mueble.

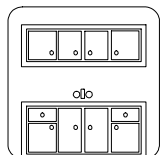

CUIDADOS:
CUIDADOS:

1) A conservação e limpeza deve ser feita com um pano levemente umedecido com água.

La conservación y limpieza debe ser hecha con un trapo levemente humedecido en agua.

2) Não use produtos abrasivos, como saponáceo, detergentes e esponja de aço.

No use productos abrasivos, como saponáceo, detergentes y esponja de acero.

3) Não use cera ou óleo para dar brilho ao móvel.

No use cera o aceites para darle brillo al mueble.



4) Não expor o móvel a interpéries e nem ao calor excessivo.

No exponer el mueble a interperies ni al calor excesivo.

5) Ao terminar a montagem, limpe o ambiente e o móvel.

Al terminar el armado, limpie al ambiente y al mueble.

FERRAMENTAS:
HERRAMIENTAS:

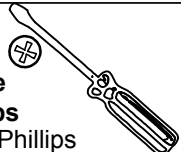
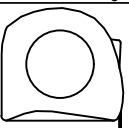





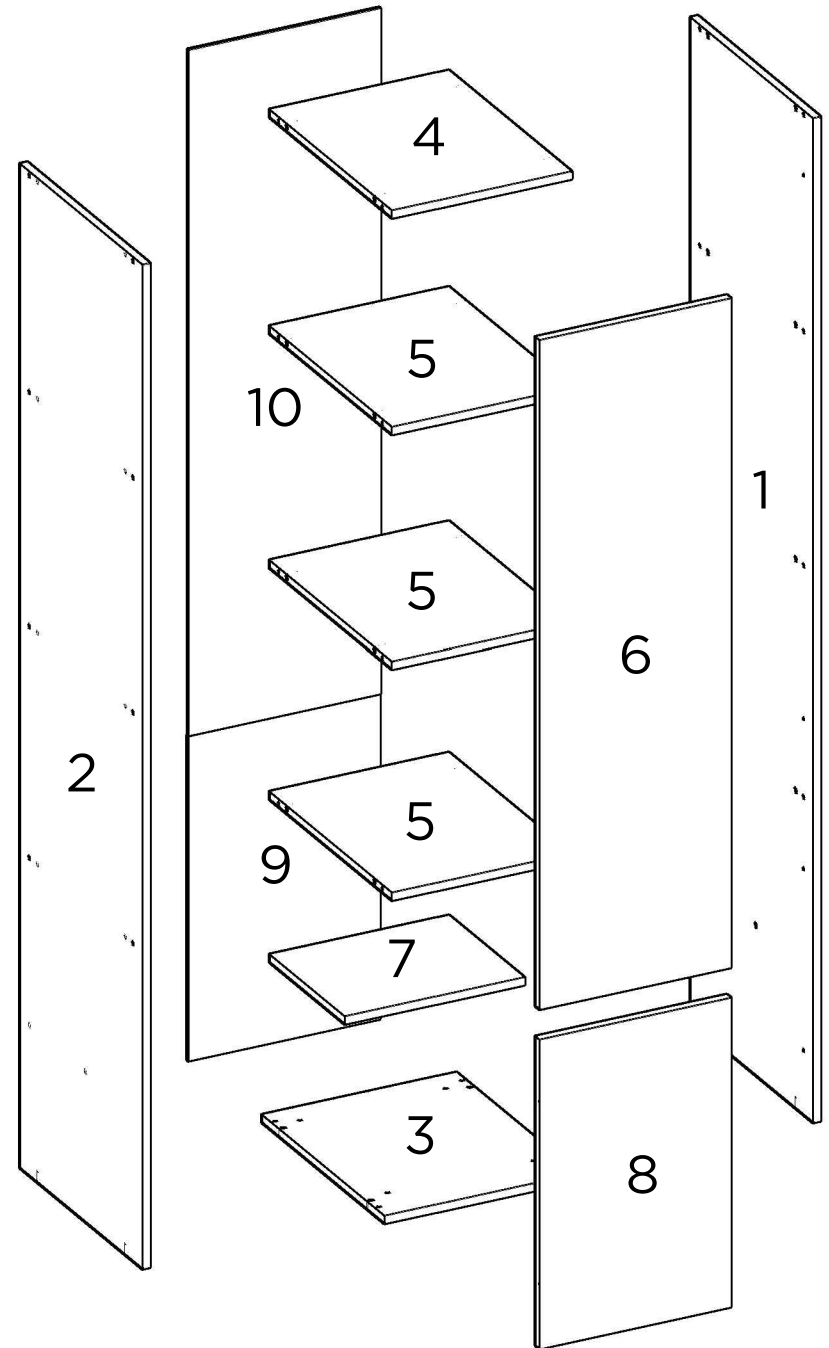



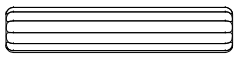

 Parafusadeira Destornillador Eléctrico	 Martelo de borracha Martillo Goma	 Martelo Martillo
 Chave Phillips Llave Phillips	 Trena Cinta métrica	

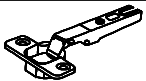
PEÇAS / PARTS / PIEZAS

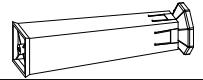
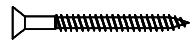
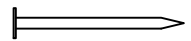
Nº No Num	DESCRIÇÃO DESCRIPTION DESCRIPCIÓN	QTD QTY CANT
1	LATERAL DIREITA RIGHT SIDE PANEL LATERAL DERECHA	1
2	LATERAL ESQUERDA LEFT SIDE PANEL LATERAL IZQUIERDA	1
3	BASE BOTTOM BASE	1
4	TAMPO TOP TABLERO	1
5	PRATELEIRA FIXA FIXED PLATE REPISA FIJO	3
6	PORTA SUPERIOR UPPER DOOR PUERTA SUPERIOR	1
7	PRATELEIRA MÓVEL MOBILE PLATE REPISA MÓVIL	1
8	PORTA DOOR PUERTA	1
9	COSTA INFERIOR LOWER BACK PANEL TRASERO INFERIOR	1
10	COSTA SUPERIOR UPPER BACK PANEL TRASERO SUPERIOR	1

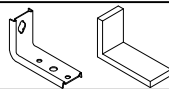

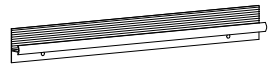
FERRAGENS / HARDWARE / HERRAJES

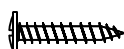
CÓD CODE COD	DESCRIÇÃO DESCRIPTION DESCRIPCIÓN	QTD QTY CANT
A	 CAVILHA WOODEN DOWEL TARUGO	20
B	 SUPORTE DE PRATELEIRA SHELF SUPPORT SOPORTE DE ESTANTES	4
C	 PARAFUSO 4X14mm SCREW 4X14mm TORNILLO 4X14mm	26
D	 CALÇO PARA DOBRADIÇA HINGE SHED CALZO DE BISAGRA	5
E	 DOBRADIÇA HINGE BIZAGRA	5
F	 PARAFUSO 5X50mm SCREW 5X50mm TORNILLO 5X50mm	5
G	 PÉ LEG PATA	4
H	 PARAFUSO 3,5X40mm SCREW 3,5X40mm TORNILLO 3,5X40mm	20
I	 PREGO NAIL CLAVO	53
J	 GARRA METÁLICA METALLIC CLAW GRAB METALICA	3
K	 SUPORTE DE FIXAÇÃO MOUNTING SUPPORT SOPORTE DE MONTAJE	1
L	 BUCHA PLÁSTICA PLASTIC BUSHING CASQUILLO PLÁSTICO	1
M	 PUXADOR PULLER TIRADOR	2
N	 PARAFUSO 3.5X25mm SCREW 3.5X25mm TORNILLO 3.5X25mm	2
O	 PARAFUSO 3.5X25mm SCREW 3.5X25mm TORNILLO 3.5X25mm	4

UTILIZE A RÉGUA PARA IDENTIFICAR OS PARAFUSOS
USE THE RULER TO IDENTIFY THE SCREWS
UTILICE LA REGLA PARA IDENTIFICAR LOS TORNILLOS

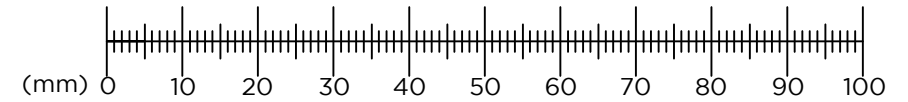

PESO SUPORTADO / WEIGHT SUPPORTED / PESO SOPORTADO

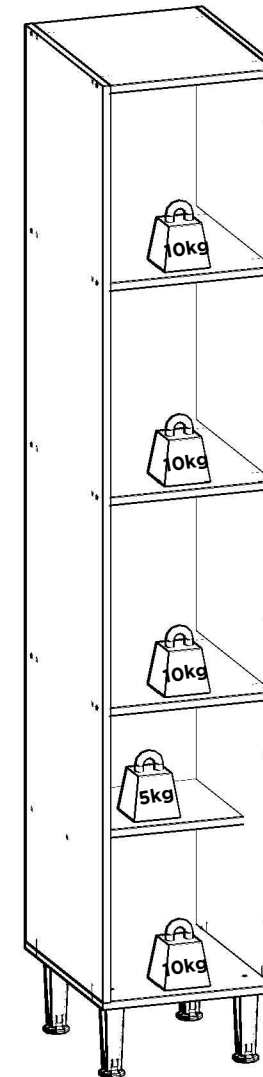

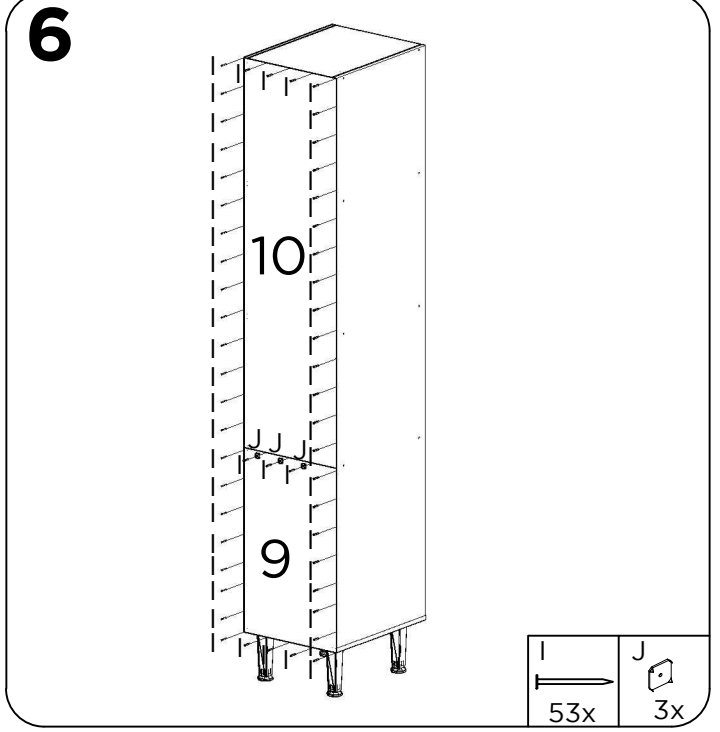
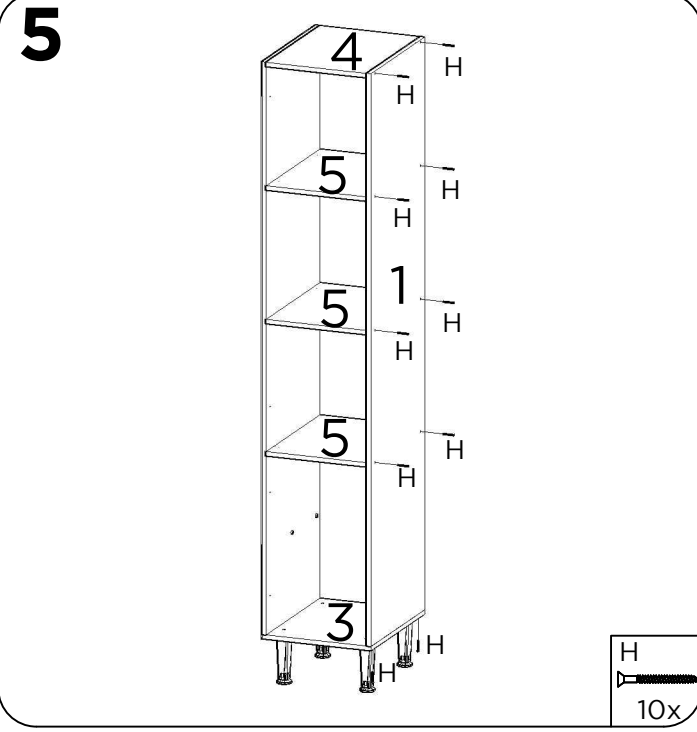
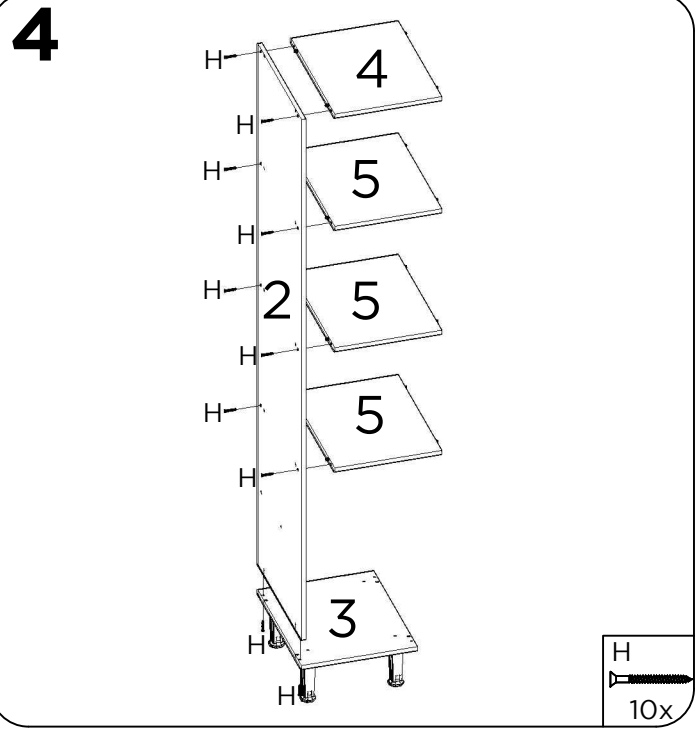
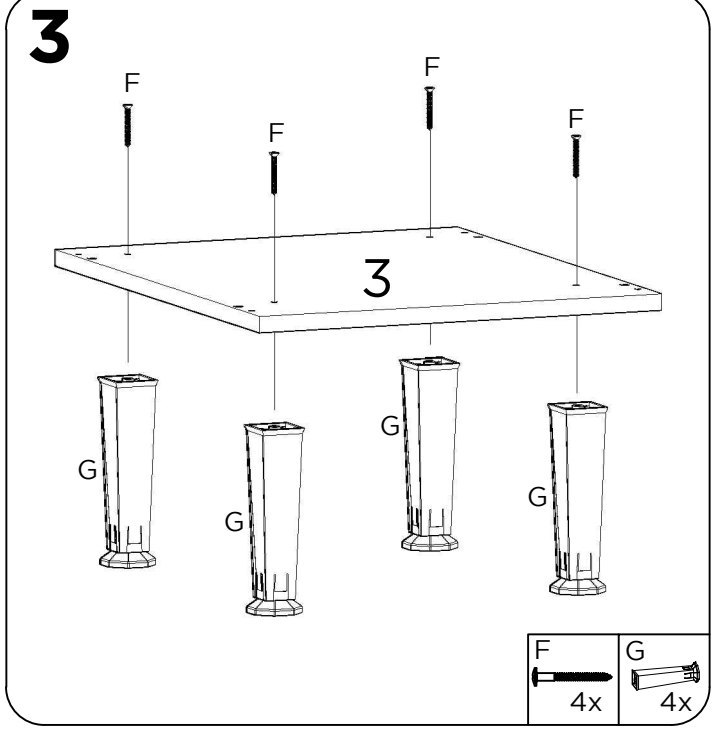
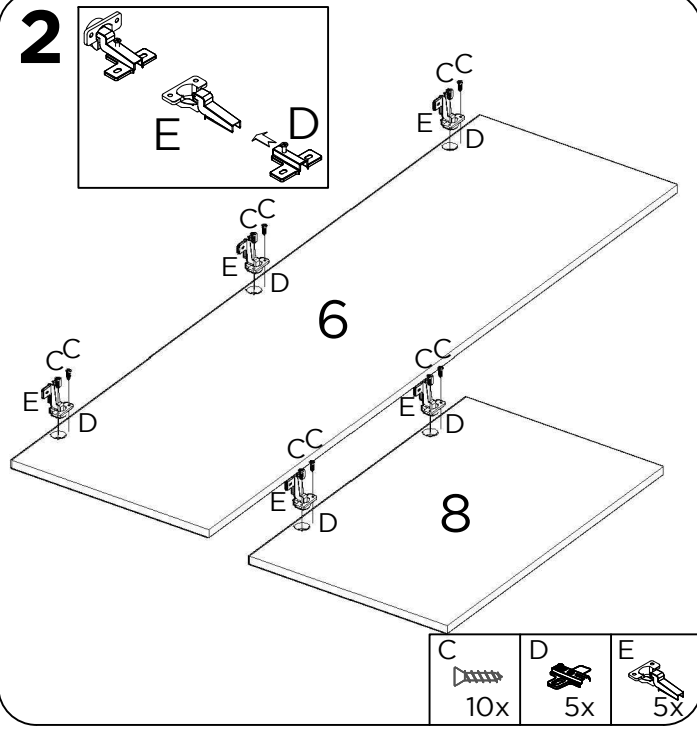
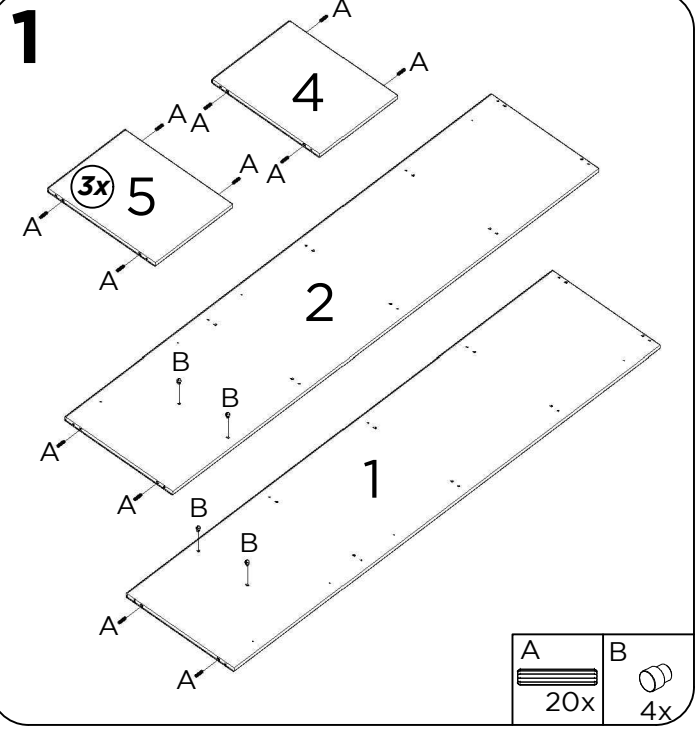

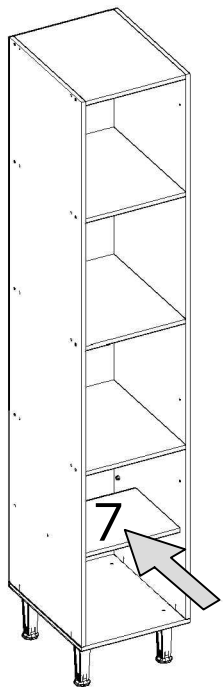
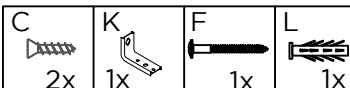
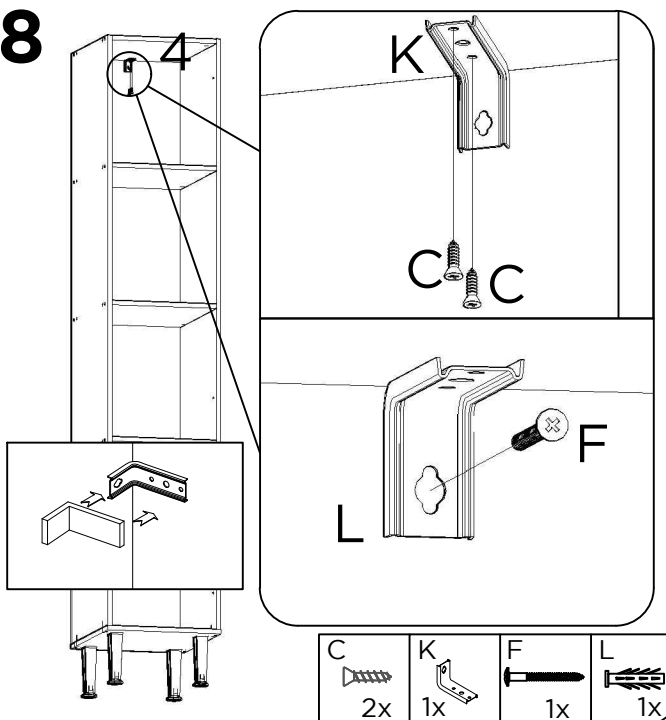
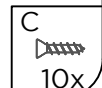
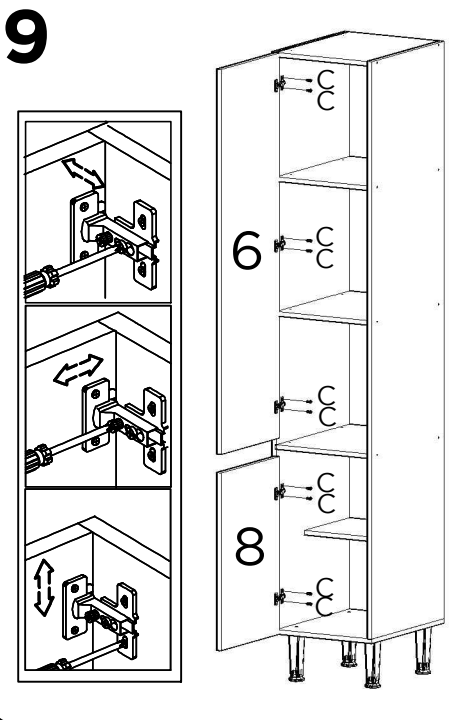
7**8****9****10**

Instalação dos puxadores conforme modelo adquirido, siga os passos no manual dos puxadores.
Instalación de las manijas según el modelo adquirido, seguir los pasos del manual de manijas.

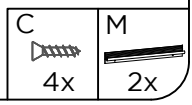
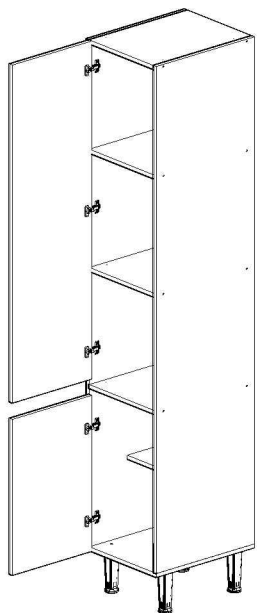
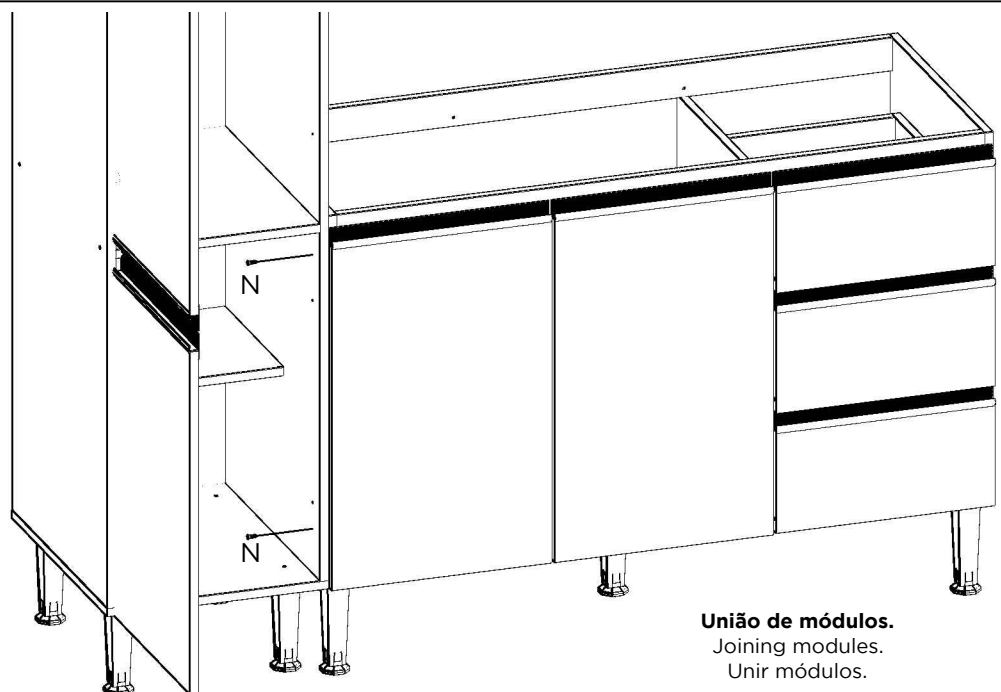
**11**

União de módulos.
 Joining modules.
 Unir módulos.

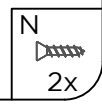

Instalação do puxador. Instalación del tirador

Siga a instrução de montagem do puxador segundo o modelo adquirido. Utilizando as respectivas ferragens.

Siga las instrucciones de montaje del tirador según el modelo adquirido. Usar correctamente la herraje.

